

CATALOGUE



Sanitary mixers



Sanitary mixers HERZ are presented in 75 countries worldwide. With the support of new investments, technologies and know how, the company has grown and developed since 1933. With the purpose of meeting ever increasing demands of present and new markets and meeting the taste of our customers, the level of quality of our sanitary mixers is being extended at all times and approaches the leading companies in our branch.

Sanitärarmaturen HERZ sind in 75 Ländern weltweit präsentiert. Anhand der Unterstützung durch neue Investitionen, Technologien und Fachkenntnisse hat das Unternehmen seit 1933 gewachsen und sich entwickelt. Mit dem Zweck, die ständig ansteigenden Anforderungen von heutigen und neuen Märkten zu erfüllen und dem Geschmack unserer Kunden nachzukommen, wird das Qualitätsniveau unserer Sanitärarmaturen ständig erhöht und nähert sich den führenden Unternehmen in unserer Branche.

Смесители HERZ представлены в 75 странах по всему миру. Компания была основана в 1933 году. Благодаря новым технологиям, инвестициям и знаниям компания постоянно растет и развивается. В целях удовлетворения растущих потребностей существующих и новых рынков, а также высоких запросов наших клиентов, уровень качества наших смесителей постоянно совершенствуется и приближается к ведущим компаниям в отрасли.

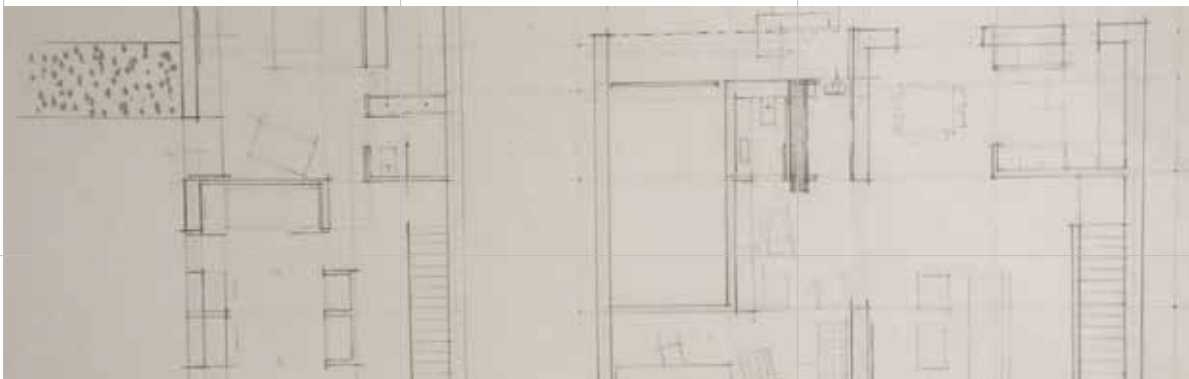



VISION

With an ever-new forms and solutions, we strive to become one of the leading, technologically advanced and internationally renowned producer of sanitary mixers with a recognizable visual concept and its own story. To identify the trends and needs of the market in the program of sanitary fittings and develop and create the products that are technologically advanced, functional and easy to use. Being a supplier of mixers, which are technologically advanced, practical, contemporary, ecological, with fresh forms, top quality, but still at affordable prices, is our vision.



VISION

Mit immer wieder neuen Formen und Lösungen sind wir bestrebt, einer der führenden, technologisch fortgeschrittenen und international angesehenen Hersteller von Sanitärarmaturen mit einem erkennbaren visuellen Konzept und eigener Geschichte zu werden. Die Trends und Bedürfnisse des Marktes im Programm von Sanitärarmaturen zu identifizieren und zu entwickeln, sowie die Produkte zu erzeugen, die technologisch, funktional und einfach zu bedienen sind. Ein Anbieter von Armaturen, die technologisch fortgeschritten, praktisch, modern, ökologisch, mit neuen Formen, Topqualität, aber immer noch zu kostengünstigen Preisen sind, zu sein, das ist unsere Vision.

КОНЦЕПЦИЯ

Среди постоянно обновляющихся форм и решений, мы стремимся стать одним из ведущих производителей смесителей, на основе передовых технологий и известности на международном рынке, со своей узнаваемой визуальной концепцией и своей историей. Выявлять тенденции и потребности рынка в области сантехнической арматуры и создавать технологичные, функциональные и простые в эксплуатации изделия. Поставлять на рынок высокотехнологичные, практичные, современные и экологичные смесители, сочетающие свежий дизайн и высокое качество с доступными ценами – в этом мы видим нашу задачу.

Herz



Sanitary mixers are produced in our contemporary equipped production and development center in Šmartno by Litija on technologically advanced processing machines. The highest quality of our products is confirmed by all major necessary European certificates.

Sanitärarmaturen sind in unserem modern ausgestatteten Produktions- und Entwicklungszentrum in Šmartno bei Litija mit technologisch hoch entwickelten Verarbeitungsmaschinen produziert. Die höchste Qualität unserer Produkte wird von allen bedeutenden notwendigen europäischen Zertifikaten bestätigt.

Смесители производятся и проектируются с использованием современного оборудования на производственном комплексе в городе Шмартно в Словении. Высокое качество нашей продукции подтверждают все основные обязательные европейские сертификаты.



More than 80 Years of experiences enable us to work with great knowledge and technology in order to be able to develop and produce the sanitary mixer of the highest quality.

Mehr als 80 Jahre Erfahrungen ermöglichen es uns, mit großem Fachwissen und der Technologie zu schaffen, um sich entwickeln und die Sanitärarmaturen von höchster Qualität herstellen zu können.

80 лет опыта работы позволяют нам, используя широкие познания и передовые технологии, разрабатывать и производить смесители самого высокого качества.





Our sanitary fittings match all required European standards; SIST EN200, SIST EN246, SIST EN248, SIST EN817, SIST EN1112 and SIST EN1113.

Unsere Sanitärarmaturen erfüllen alle erforderlichen europäischen Normen:

SIST EN200, SIST EN246, SIST EN248, SIST EN817, SIST EN1112 und SIST EN1113.

Наша сантехническая продукция выполняет все обязательные требования европейских стандартов: SIST EN200, SIST EN246, SIST EN248, SIST EN817, SIST EN1112 и SIST EN1113.



OUR MISSION

To recognize and identify the trends in our operating environment and based on recognized requirements of users and markets, to develop solutions in the form of products which are technologically advanced, sophisticated, contemporary in design but still simple and practical to use.

UNSERE MISSION

Die Trends in unserer Arbeitsumgebung und auf Basis anerkannter Anforderungen der Benutzer und Märkte zu erkennen und zu identifizieren, die Lösungen in Form von Produkten, die technologisch hoch entwickelt, anspruchsvoll, modern gestaltet, aber immer noch einfach und praktisch in der Anwendung zu entwickeln.

МИССИЯ

Выявлять тенденции развития в отрасли и, исходя из существующих потребностей пользователей и рынков, предлагать новые решения в виде изделий, сочетающих технологичность, функциональность и современный дизайн с практичностью и простотой в эксплуатации.



Ecology

Reduce your water consumption and save with use of water saving set HERZ. The Eco set contains two ECO aerators that enable water flow of 6 l/minute and water flow regulator for the shower that enables the water flow of 9 l/minute. Eco set is possible to use at all lines of sanitary mixers HERZ.

Reduzieren Sie Ihren Wasserverbrauch und sparen Sie mit der Nutzung der Wassersparsatz HERZ. Der Eco-Satz enthält zwei ECO-Belüfter, die einen Wasserdurchfluss von 6 l/min, und einen Wasserdurchflussregler für die Dusche, der einen Wasserdurchfluss von 9 l/min ermöglicht. Eco-Satz kann auf allen Linien der HERZ-Sanitärarmaturen verwendet werden.

Сократить потребление воды и добиться экономии затрат с помощью водосберегающих решений HERZ. В набор Eco входят два аэратора ECO, обеспечивающие подачу воды 6 л/мин, а также регулятор потока для душа, обеспечивающий подачу 9 л/мин. Набор Eco можно использовать на смесителях всех серий HERZ.



Trade mark of bathroom and kitchen mixers of the highest quality.

Warenzeichen für Bad- und Küchenarmaturen von höchster Qualität.

Марка смесителей высочайшего качества для кухни и ванной комнаты.

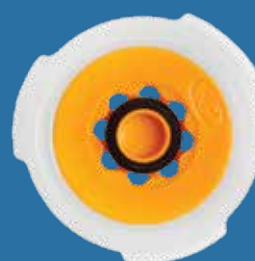
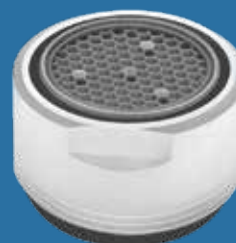



ENVIRONMENTAL CONCERN AND AWARENESS

To our company represents a prudent use of resources and energy, environmentally friendly methods of production and care for the environment, part of social responsibility and awareness.

Using environmentally friendly packaging, promotional materials and recycled materials, represents only a part of our environmental responsibility, which is dedicated to materials that we use. This is followed, of course, by environmentally friendly production methods; Modern galvanization line, waste water treatment, re-use of waste materials, round up the social and environmentally responsible management of our company.

Another focus of our environment concern is intended foremost to safety and energy conservation. Emphasis is given to the solutions in the form of products, which are mainly focused on deliberate approach to water consumption savings, energy efficiency and energy saving and thereby conserving natural resources. Our aim is a high quality, safe and economical product that provides an efficient use for years to come.

UMWELTBEDENKEN UND UMWELTBEWUSSTSEIN

Ein umsichtiger Einsatz von Ressourcen und Energie, umweltfreundliche Produktionsmethoden und Sorge für die Umwelt stellen für unseres Unternehmen einen Teil der sozialen Verantwortung und Bewusstseins dar.

Die Verwendung umweltfreundlichen Verpackungen, Werbematerialien und recycelten Materialien stellt nur einen Teil unserer Umweltverantwortung, die den von uns verwendeten Materialien gewidmet ist, dar. Dies wird natürlich durch umweltfreundliche Produktionsmethoden gefolgt; moderne Verzinkungslinie, Abwasserbehandlung, Wiederverwertung von Abfallmaterialien, runden das soziale und umweltverantwortliche Management unseres Unternehmens auf.

Ein weiterer Schwerpunkt unserer Umweltbedenken wird vor allem für die Sicherheit und Energieeinsparung zgedacht. Die Betonung wird den Lösungen in Form von Produkten gegeben, die vor allem auf absichtlichen Ansatz zur Wasserverbrauchseinsparung, Energieeffizienz und Energieeinsparung und damit der Schonung der natürlichen Ressourcen ausgerichtet sind. Unser Ziel ist ein hochwertiges, sicheres und wirtschaftliches Produkt, das eine effiziente Nutzung für die kommenden Jahre bereitstellt.

ЗАБОТА ОБ ОКРУЖАЮЩЕЙ СРЕДЕ

Наша компания выступает за рациональное использование ресурсов и энергии, экологичные методы производства, уход за окружающей средой и социальную ответственность.

Использование экологичной упаковки и рекламных материалов, а также применение повторно переработанных материалов – это лишь часть нашей заботы об окружающей среде, которая проявляется во всех наших материалах. Кроме этого, мы, естественно, используем экологически чистые технологии: современная линия гальванизации, очистка сточных вод, повторное использование отходов производства, а также социально и экологически ответственные методы управления компанией.

Еще одно направление нашей экологической деятельности – обеспечение безопасности и сохранение энергии. При этом особое внимание уделяется тем решениям в нашей продукции, которые прежде всего основаны на продуманном подходе к потреблению воды и эффективности энергопотребления, и тем самым способствуют сохранению природных ресурсов. Наша цель - высокое качество, безопасность и экономичность производства, что обеспечивает эффективный расход ресурсов на многие годы.

Index
Index
Содержание

Index



Design series

Kitchen
&
Bathroom

Infinity	12
Fresh	22
Thermostatic	32
Sensor	34

Classic series

Kitchen
&
Bathroom



Prestige	42
Harmony	48
Project	52
Simpaty	56
Stil	64
Classic	72

Showers

Design
&
Classic



Design Showers	78
Classic Showers	88



Design series

Concealed
mixers

Concealed mixers	92
Accessories	98

Accessories 100



Valves	102
Siphons	104
Accessories	108



Drawings 110

Index 131





design *series*

Kitchen &
bathroom

Sanitary kitchen mixers

Sanitärarmaturen für Küche

Смесители для кухни

Infinity



INFINITY sanitary kitchen mixers

Infinity kitchen mixers with their modern lines and simplicity of use can be easily placed into any contemporary kitchen. The combination of straight and curved lines appears elegant, but yet contemporary. Sophisticated design united with deliberate solutions and range of possibilities in different spouts offering the optimal choice for reliability and the freedom of use in your kitchen.

Our assortment of INFINITY kitchen mixers includes the models with three types of fully movable spouts and side handles that can be used on the left or right side.

INFINITY sanitäre Küchenarmaturen

Infinity Küchenarmaturen mit ihren modernen Linien und Schlichtheit in der Anwendung können problemlos in jede moderne Küche platziert werden. Die Kombination von geraden und gerundeten Linien erscheint elegant, aber dennoch modern. Anspruchsvolles Design vereint mit durchdachten Lösungen und eine Palette von verschiedenen Ausläufen bieten eine optimale Wahl für die Zuverlässigkeit und die Freiheit der Verwendung in der Küche.

Кухонные смесители INFINITY

Кухонные смесители Infinity – это современные линии и простота эксплуатации, что позволяет легко установить их в любой современной кухне. Сочетание прямых и изогнутых линий выглядит элегантно, но в то же время и современно. Утонченный дизайн в сочетании с продуманными решениями и возможностью выбора различных изливов – оптимальный выбор, обеспечивающий надежность и свободу на вашей кухне. В серию кухонных смесителей Infinity входят различные модели с тремя типами полностью подвижных изливов. При этом боковые ручки можно использовать как с левой, так и с правой стороны.



i20

Infinity i20

Sanitary kitchen mixer
Sanitär-Küchenarmatur
Кухонный смеситель

Drawing: p. 112



00170 00169 01169

-  angle valves
Eckventile
Угловые вентили
-  only mixers
nur Armatur
Только смеситель
-  low pressure version
Niederdruckversion
версия низкого давления

Sanitary kitchen mixers

Sanitärarmaturen für Küche

Смесители для кухни

Infinity

i23



Infinity i23

Sanitary kitchen mixer
Sanitär-Küchenarmatur
Кухонный смеситель

Drawing: p. 113



00176 00175 01175

 angle valves
Eckventile
Угловые вентили

 only mixers
nur Armatur
Только смеситель

 low pressure version
Niederdruckversion
версия низкого давления



i21



i22

Infinity i21

Sanitary kitchen mixer
Sanitär-Küchenarmatur
Кухонный смеситель

Drawing: p. 112, 113



00172 00171 01171

Infinity i22

Sanitary kitchen mixer
Sanitär-Küchenarmatur
Кухонный смеситель

Drawing: p. 113



00174 00173 01173

Bathroom mixers

Badarmaturen
Смесители для ванной

Infinity

i10



i12



All basin mixers include eco aerator that enables the water flow of 6 l/min.

Alle Waschbeckenarmaturen enthalten einen eco-Belüfter, der einen Wasserdurchfluss von 6 l/min ermöglicht.

Все миксеры для умывальника оснащаются насадкой-аэратором ECO, которая обеспечивает расход воды 6 л/мин.

Infinity i10

Basin mixer

Waschbeckenarmatur

Смеситель для умывальника

Drawing: p. 112



00004 00002 00003 00001

Infinity i12

Basin mixer; higher version

Waschbeckenarmatur; erhöhte

Смеситель для умывальника –
высокий вариант

Drawing: p. 112



00014 00012 00013 00011



with waste
Abfall
Со стоком



angle valves
Eckventile
Угловые вентили



with waste, siphon, angle valves
Abfall, Siphon, Eckventile.

Сток, сифон, угловые вентили



only mixers
nur Armatur
Только смеситель



low pressure version
Niederdruckversion
ерсия низкого давления

INFINITY basin mixers

Elegant combining of straight and curved lines supplemented with care for the environment by water saving ECO aerators, pampers you in your daily use. The mixer is fitted with an aerator of the highest quality that enables the water flow of 6l per minute. INFINITY basin mixer therefore represents an elegant and useful blend of modern design and care for the environment at the same time.

INFINITY Waschbeckenarmaturen

Elegante Kombination von geraden und gerundeten Linien, mit Sorgfalt für die Umwelt durch Wasser sparenden ECO-Belüfter ergänzt, verwöhnt Sie in Ihrem täglichen Gebrauch. Die Armatur ist mit einem Belüfter von höchster Qualität, der eine Wasserdurchfluss von 6 l pro Minute ermöglicht, ausgestattet. INFINITY Waschbeckenarmatur stellt somit eine elegante und nützliche Mischung von modernem Design und Sorge für die Umwelt zur gleichen Zeit dar.

Смесители для умывальника INFINITY

Элегантное сочетание прямых и изогнутых линий, а также забота об окружающей среде путем экономии воды с помощью аэраторов ECO для вашей повседневной жизни. Смеситель оснащен аэратором высочайшего качества, который обеспечивает расход воды 6 литров в минуту.

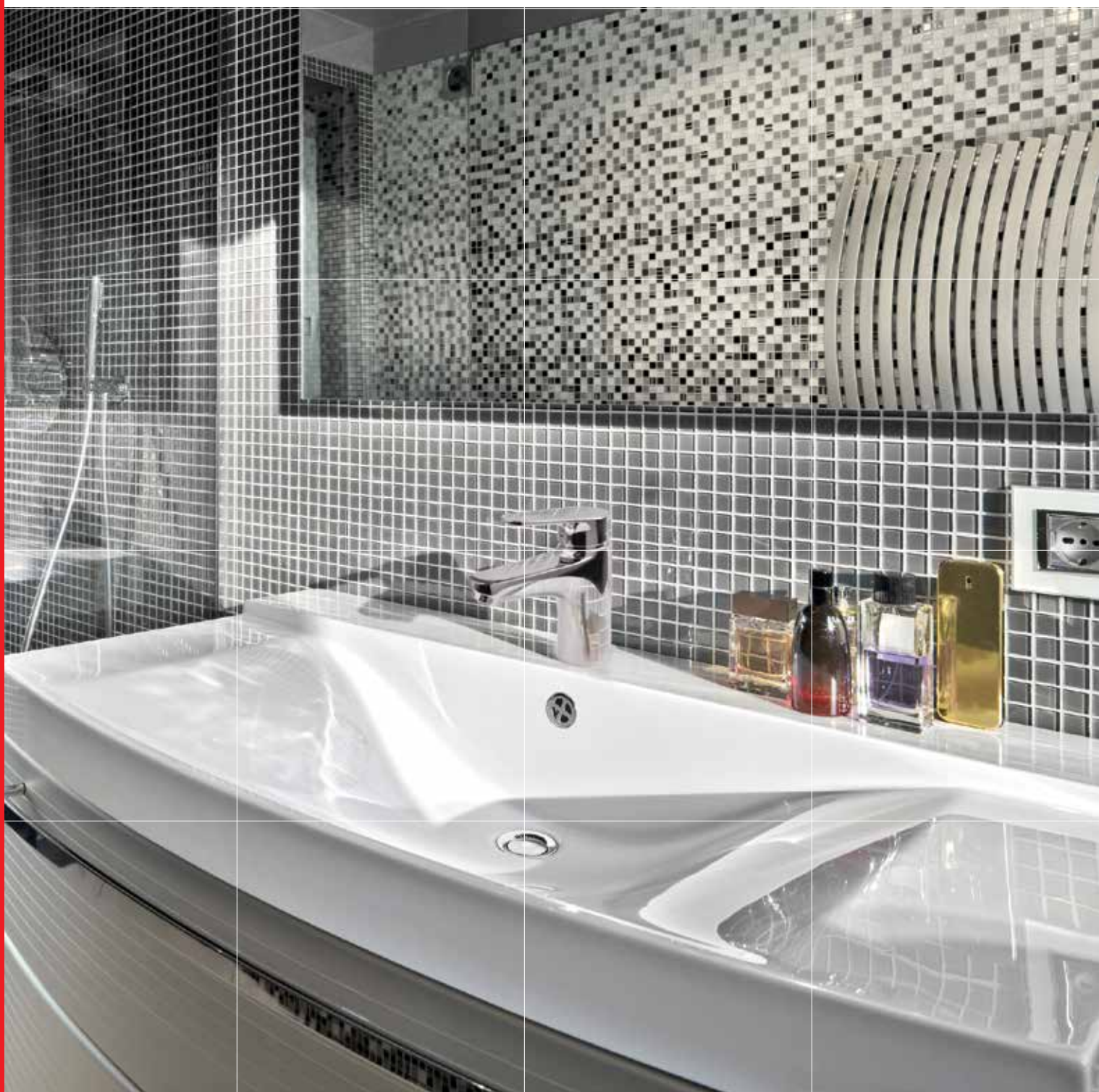

Bathroom mixers

Badarmaturen
Смесители для ванной

Infinity



Infinity i50

Bidet mixer

Bidetarmatur

Смеситель для биде

Drawing: p. 112



00503 00501



i50



with waste
Abfall
Со стоком



angle valves
Eckventile
Угловые вентили



with waste, siphon, angle valves
Abfall, Siphon, Eckventile.
Сток, сифон, угловые вентили



only mixers
nur Armatur
Только смеситель



low pressure version
Niederdruckversion
ерсия низкого давления



All basin mixers include eco aerator that enables the water flow of 6 l/min.
Alle Waschbeckenarmaturen enthalten einen eco-Belüfter, der einen
Wasserdurchfluss von 6 l/min ermöglicht.

Все миксеры для умывальника оснащаются насадкой-аэратором ECO,
которая обеспечивает расход воды 6 л/мин.

Bathroom mixers

Badarmaturen
Смесители для ванной

Infinity



i30

Infinity i30

Bath/shower mixer
Wannen-/Duscharmatur
Смеситель для ванны/душа

Drawing: p. 113



00301 00302 00303



Bath/shower mixers and shower mixers with shower set include water flow regulator that enables the water flow of 9l/minute.

Bad / Dusche Armaturen und Duscharmaturen mit Duschgarnitur enthalten Wassermengenregler, der den Wasserdurchfluss von 9 l / min ermöglicht.
Смесители для ванны/душа и смеситель для душа включают регулятор потока, обеспечивающий подачу воды 9 л/мин.



i40

Infinity i40

Shower mixer
Duscharmatur
Смеситель для душа

Drawing: p. 113



00401 00402 00403

 only mixers
nur Armatur
Только смеситель

 shower head
Brausekopf,
Насадка душа

 Shower head, hose and shower rail
Brausekopf, Brauseschlauch und Brausestange
Насадка, шланг и рейлинг для душа

Sanitary kitchen mixers

Sanitärarmaturen für Küche
Смесители для кухни

Fresh





f22

f42

f32

Fresh f22

Kitchen mixer – flexible spout
 Küchenarmatur - flexibler Auslauf
 Кухонный смеситель – гибкий излив
 Drawing: p. 114, 115



00136 00135 01138

Fresh f32

Kitchen mixer – flexible spout
 Küchenarmatur - flexibler Auslauf
 Кухонный смеситель – гибкий излив
 Drawing: p. 115



00147 00145 01146

Fresh f42

Kitchen mixer – flexible spout
 Küchenarmatur - flexibler Auslauf
 Кухонный смеситель – гибкий излив
 Drawing: p. 116



00146 00144 01145



angle valves
 Eckventile
 Угловые вентили



only mixers
 nur Armatur
 Только смеситель



low pressure version
 Niederdruckversion
 версия низкого давления

Sanitary kitchen mixers

Sanitärarmaturen für Küche

Смесители для кухни

Fresh



FRESH kitchen mixers

Their sophisticated design and interlacement of round lines, which can be blend in any modern kitchen is in the range of FRESH kitchen mixers combined with a wide range of practical solutions. High, movable spouts, pull-out showers are just some of the solutions that allows creativity and simplicity of use of mixers from Fresh line. Special solution, presented in this line of kitchen mixers is the mixer with the special spout that can be folded in the cases when your kitchen sink is placed directly at the window. Spout, which can be folded, enables you to open and close your windows at any time without problems. In this line you can also find a thermostatic variant of kitchen mixer that offers you the comfort of use, saving of hot water and safety from water scalding.

FRESH Küchenarmaturen

Ihr anspruchsvolles Design und Verflechtung von gerundeten Linien, die in jeder modernen Küche einblenden können, ist im Bereich von FRESH Küchenarmaturen mit einer Vielzahl von praktischen Lösungen kombiniert. Hohe, bewegliche Ausläufe und ausziehbare Brausen sind nur einige der Lösungen, die Kreativität und Schlichtheit in der Anwendung von Fresh Armaturen ermöglichen. Eine Sonderlösung, die in dieser Linie der Küchenarmaturen dargestellt wird, ist die Armatur mit einem speziellen Auslauf, der zusammengeklappt werden kann, wenn Sie Ihre Küchenspüle direkt am Fenster platziert ist. Der zusammenklappende Auslauf ermöglicht Ihnen, Ihre Fenster zu jeder Zeit ohne Probleme zu öffnen und zu schließen. In dieser Linie finden Sie auch eine thermostatische Variante der Küchenarmatur, die Ihnen einen Nutzungskomfort, Einsparung von heißem Wasser und Sicherheit vor Verbrühungen durch heißes Wasser anbieten.

Кухонные смесители FRESH

Утонченный дизайн и переплетения скругленных линий, которые вольются в любую современную кухню, в серии кухонных смесителей FRESH сочетаются с широким диапазоном практических решений. Высокий подвижный излив, выдвигаемая лейка – это лишь некоторые из решений, сочетающих креативность и простоту эксплуатации смесителей серии Fresh. Особое решение, примененное в этой серии кухонных смесителей – специальный излив, который можно сложить в тех случаях, когда кухонная раковина размещается непосредственно у окна. Складывающийся излив позволит в любое время без проблем открыть и закрыть окно. В этой серии также предлагается термостатический вариант кухонного смесителя, сочетающий удобство в пользовании и экономию горячей воды, а также защиту от водных ожогов.



f21

f41

f31

Fresh f21

Sanitary kitchen mixer
Sanitär-Küchenarmatur
Кухонный смеситель

Drawing: p. 114



00133 00134 01137

Fresh f31

Sanitary kitchen mixer
Sanitär-Küchenarmatur
Кухонный смеситель

Drawing: p. 115



00131 00132 01144 01143

Fresh f41

Sanitary kitchen mixer
Sanitär-Küchenarmatur
Кухонный смеситель

Drawing: p. 116



00129 00130 01142 01141

-  angle valves
Eckventile
Угловые вентили
-  only mixers
nur Armatur
Только смеситель
-  low pressure version
Niederdruckversion
версия низкого давления

Sanitary kitchen mixers

Sanitärarmaturen für Küche

Смесители для кухни

Fresh



f20

Fresh f20

Kitchen mixer with pullout spray

Küchenarmatur mit Auszugsbrause

Кухонный смеситель с

выдвижной лейкой

Drawing: p. 114



00138 00137

Uniquely designed shape of mixer that enables to direct the water jet randomly in the harder reachable parts of dishes. Ideal for deeper kitchen sinks
Easy opening.

Einzigartig konzipierte Form der Armatur, die einen Wasserstrahl nach dem Zufallsprinzip in die schwierig erreichbaren Teile des Geschirrs zu richten ermöglicht. Ideal für tiefere Küchenspülen
Leicht zu öffnen.

Уникальный дизайн смесителя позволяет направить струю воды в любую сторону и добраться до труднодоступных мест. Идеально подходит для глубоких кухонных раковин
Легко открывается.



angle valves
Eckventile
Угловые вентили



only mixers
nur Armatur
Только смеситель



low pressure version
Niederdruckversion
версия низкого давления



f23



Fresh f23

Thermostatic kitchen mixer
Thermostatische Küchenarmaturen
Термостатический кухонный
смеситель
Drawing: p. 115



00235

Bathroom mixers

Badarmaturen
Смесители для ванной

Fresh

f10



f11



Fresh f10

Basin mixer
Waschbeckenarmatur
Смеситель для умывальника
Drawing: p. 113, 114



00039 00038 00040 00035 01035

Fresh f11

Basin mixer; higher version
Waschbeckenarmatur; erhöhte
Смеситель для умывальника
– высокий вариант
Drawing: p. 114



00048 00049



with waste
Abfall
Со стоком



angle valves
Eckventile
Угловые вентили



with waste, siphon, angle valves
Abfall, Siphon, Eckventile.
Сток, сифон, угловые вентили



only mixers
nur Armatur
Только смеситель



low pressure version
Niederdruckversion
ерсия низкого давления

FRESH sanitary mixers for bathroom

The modern, trendy, curved lines, perfection of details and several variations of basin mixers in this range, provide an assurance that this family of mixers can be easily fitted in any modern bathroom. Perfection of design and usability that offers satisfaction in everyday use.

FRESH sanitäre Badarmaturen

Die modernen, modischen, gerundeten Linien, Perfektion der Details und mehrere Variationen von Waschbeckenarmaturen in dieser Palette bieten eine Garantie dafür, dass diese Familie von Armaturen problemlos in jedes moderne Bad eingebaut werden kann. Perfektion von Design und Benutzerfreundlichkeit, die eine Zufriedenheit im Alltagsgebrauch bietet.

Смеситель для ванной FRESH

Современный, модный дизайн, изогнутые линии, совершенство деталей, несколько вариантов смесителей для умывальника в этой серии обеспечивают уверенность при установке в любой современной ванной комнате. Совершенный дизайн и практичность - удовлетворение в повседневной эксплуатации.

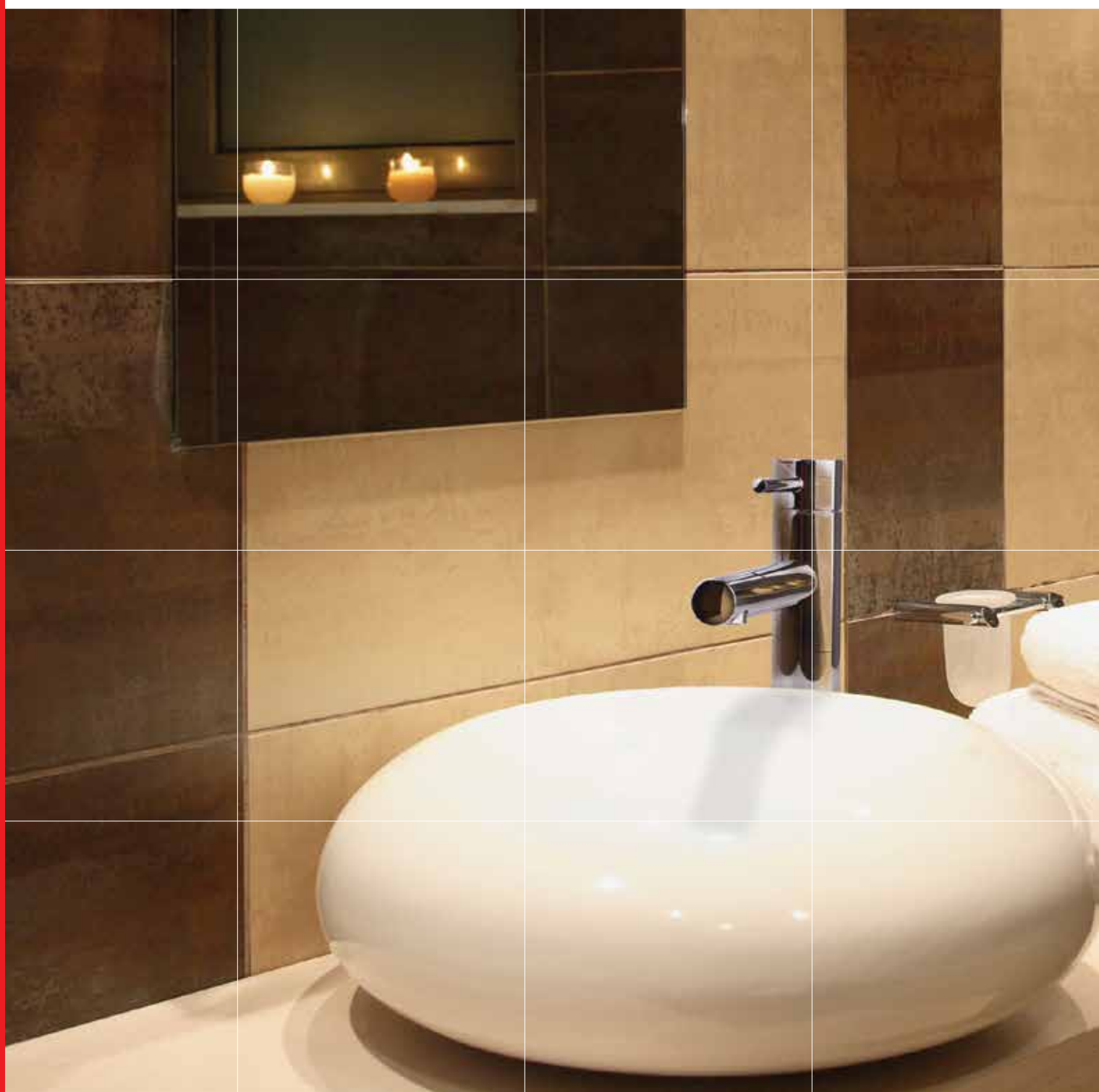

Bathroom mixers

Badarmaturen
Смесители для ванной

Fresh



f12

Fresh f12

Basin mixer
Waschbeckenarmatur
Смеситель для умывальника

Drawing: p. 114



00045 00044

Fresh f50

Bidet mixer
Bidetarmatur
Смеситель для биде

Drawing: p. 114



00537 00536 00535



f50



with waste
Abfall
Со стоком



angle valves
Eckventile
Угловые вентили



with waste, siphon, angle valves
Abfall, Siphon, Eckventile.
Сток, сифон, угловые вентили



only mixers
nur Armatur
Только смеситель



low pressure version
Niederdruckversion
версия низкого давления



f30

Fresh f30

Bath/shower mixer
Wannen-/Duscharmatur
Смеситель для ванны/душа

Drawing: p. 115







Fresh f40

Shower mixer
Duscharmatur
Смеситель для душа

Drawing: p. 115



f40

-  only mixers
nur Armatur
Только смеситель
-  with waste, siphon, angle valves
Abfall, Siphon, Eckventile.
Сток, сифон, угловые вентили
-  low pressure version
Niederdruckversion
ерсия низкого давления
-  shower head
Brausekopf,
Насадка душа
-  Shower head, hose and shower rail
Brausekopf, Brauseschlauch und Brausestange
Насадка, шланг и рейлинг для душа

Bathroom mixers

Badarmaturen
Смесители для ванной

Fresh



t30



Fresh t30

Thermostatic bath mixer
Thermostatische Wannenarmatur
Термостатический смеситель
для ванны
Drawing: p. 116



00339 00336



FRESH thermostatic mixers

The elegant, prestigious, round lines, is in family FRESH wonderfully complemented by the exceptional usability of thermostatic mixers; Comfort and safety of use that is provided by the setting of the required water temperature, is intertwined with practicality which is offered by saving of the used quantity of hot water. The offered safety from water scalding is especially valuable for families with small children. The surface of the fitting it is also safe to touch, because it doesn't overheat itself during the use.

FRESH thermostatische Armaturen

Die eleganten, prestigeträchtigen, runden Linien sind in der Familie FRESH wunderbar durch die außergewöhnliche Benutzerfreundlichkeit der thermostatischen Armaturen ergänzt; Komfort und Sicherheit der Anwendung, die durch die Einstellung der gewünschten Wassertemperatur gewährt ist, wird mit Funktionalität, die durch die Einsparung der verwendeten Heißwassermengen angeboten wird, verflochten. Die angebotene Sicherheit vor Verbrühungen durch heißes Wasser ist vor allem für Familien mit kleinen Kindern wertvoll. Die Oberfläche des Beschlages ist ebenfalls berührungssicher, weil sie sich während der Verwendung nicht überhitzt.

Термостатические смесители FRESH

Элегантность, престиж и скругленные линии серии FRESH чудесно дополняют исключительно практичные термостатические смесители: комфорт и безопасность эксплуатации достигаются установкой требуемой температуры воды, в сочетании с практичностью благодаря сокращению расхода горячей воды. Предотвращение ожогов от воды будет особенно полезно для семей с маленькими детьми. Кроме того, поверхность изделия также можно безопасно трогать, поскольку она не перегревается во время эксплуатации.



Fresh t40

Thermostatic Shower mixer

Thermostatic Shower mixer

Термостатический смеситель

для душа

Drawing: p. 116



00440 00437



only mixers
nur Armatur
Только смеситель



shower head
Brausekopf,
Насадка душа



Shower head, hose and shower rail
Brausekopf, Braueschlauch und Brauestange
Насадка, шланг и рейлинг для душа

Sensor mixers

Sensorarmaturen
Сенсорные смесители

Fresh

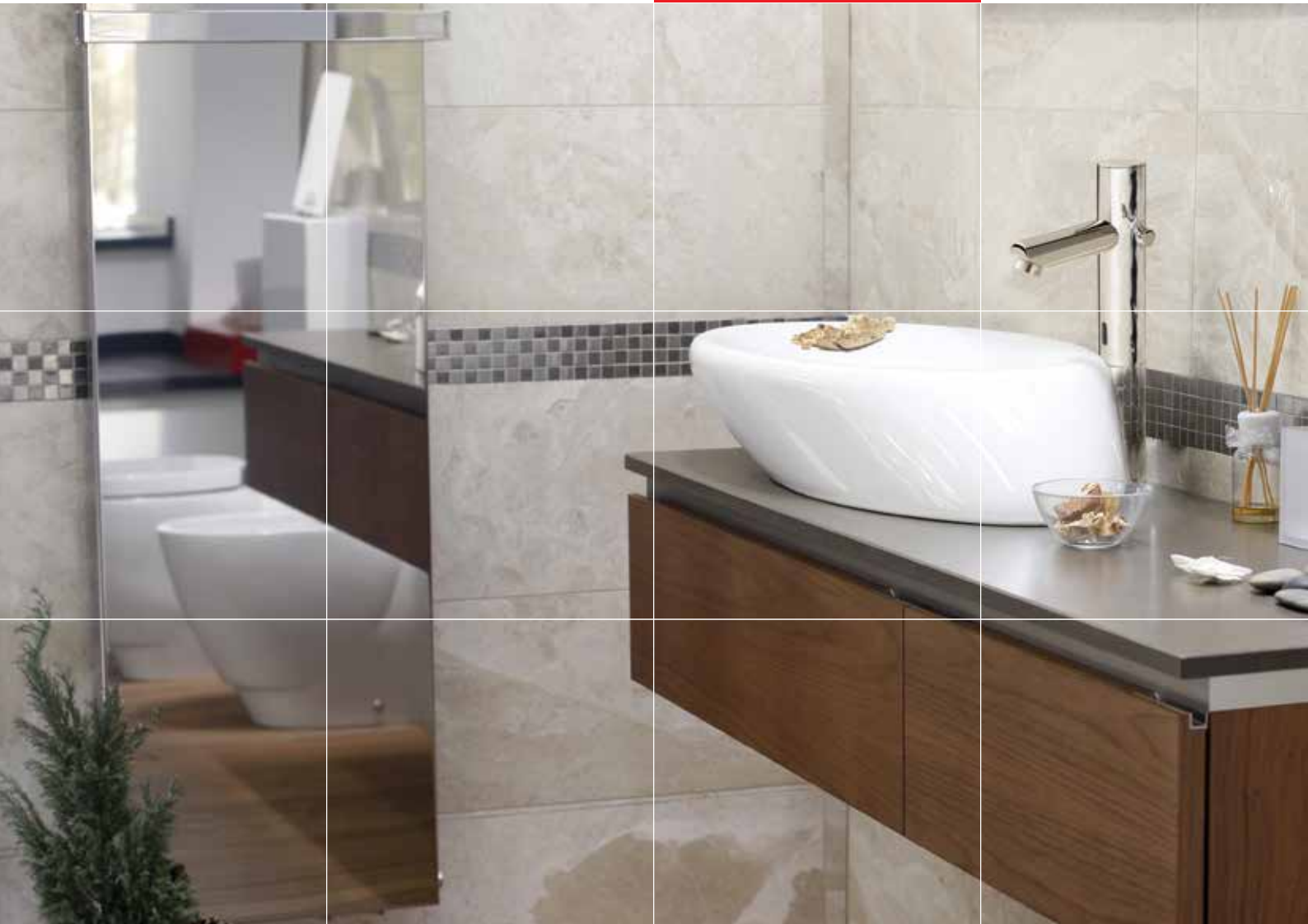

FRESH IR

When well thought out and sophisticated shape of family FRESH, is combined with first-class functionality of sensor mixer. Sensor mixers in addition to the hygiene aspect which they put to good advantage in hospitals and public places, provide also to our end users the comfort and safety with possibility of setting the water temperature. Significant saving aspect presents one of additional reasons why more and more of our customers decide to use a sensor mixer also at home. In our assortment of top quality sensor mixers FRESH, the mixing as well as non-mixing taps can be found. They are of various shapes and designs, have possibility of battery, as well as the network version.

FRESH IR

Wenn gut durchdachte und anspruchsvolle Form der Familie FRESH mit einer erstklassigen Funktionalität der Sensorarmatur kombiniert. Neben dem Hygieneaspekt, der einen guten Vorteil für Krankenhäuser und öffentlichen Plätzen setzt, garantieren die Sensorarmaturen auch für unsere Endkunden den Komfort und Sicherheit mit der Möglichkeit einer Wassertemperatureinstellung. Erhebliche Einsparungen stellen einen weiteren Grund dafür, dass sich immer mehr unserer Kunden entscheiden, eine Sensorarmatur auch zu Hause zu verwenden. In unserem Sortiment von hochwertigen FRESH Sensorarmaturen können sowohl Mischarmaturen als auch Nicht-Mischarmaturen gefunden werden. Sie sind in verschiedenen Formen und Designs, mit einer Möglichkeit der Batterie, oder aber als Netzwerkversion erhältlich.

FRESH IR

Тщательно продуманные, сложные формы серии FRESH в сочетании с максимальной функциональностью сенсорного смесителя. Сенсорные смесители хорошо дополняют гигиенические факторы, что дает им значительное преимущество в больницах и в общественных местах, а также обеспечивает пользователям комфорт и безопасность с возможностью установки температуры воды. Значительная экономия – еще одна причина, почему все больше и больше наших клиентов ставят сенсорные смесители у себя дома. В нашем ассортименте высококачественных сенсорных смесителей FRESH также присутствуют несмешивающие краны. Они имеют различную форму и конструкцию и предлагаются с батареей или в сетевом варианте.

e10



Fresh e10

Sensor basin mixer
Sensor-Waschbeckenarmatur
Сенсорный смеситель для
умывальника

Drawing: p. 116



09016 09017

e11

FRESH IR for cold or preset
water; battery powering
9V/230V Programming
electronic

FRESH IR für kaltes oder
voreingestelltes Wasser;
Batteriestromversorgung
9V/230V elektronische
Programmierung

Изделия FRESH IR –
холодная вода или заданная
температура; питание
от батарейки 9V/230V,
программная электроника

Fresh e11

Sensor basin mixer –high version
Sensor-Waschbeckenarmatur –
erhöhte Version

Сенсорный смеситель для
умывальника – высокий
вариант

Drawing: p. 116



09020 09021

e16



Fresh e15

Sensor basin mixer
Sensor-Waschbeckenarmatur
Сенсорный смеситель для
умывальника

Drawing: p. 117



09018 09019

e15



Fresh e16

Sensor basin mixer –high version
Sensor-Waschbeckenarmatur –
erhöhte Version

Сенсорный смеситель для
умывальника – высокий
вариант

Drawing: p. 117



09022 09023

Sensor mixers

Sensorarmaturen
Сенсорные смесители

Fresh



Fresh e50

Urinal sensor flusher/battery
version

Urinal Sensorspüler /
Batterieversion

Сенсорный смыватель
для писсуара / версия с
батарежкой

Drawing: p. 117

9V

09510

e50

Fresh e66

Concealed urinal sensor flusher
-Installation set

Unterputz - Urinal Sensorspüler
Einbauset

Скрытый сенсорный смыватель
для писсуара Монтажный
комплект

Drawing: p. 129



09511 09512

e66

09511

Concealed, 1/2", 9 V without cover plate
Unterputz, 1/2", 9 V ohne Abdeckplatte
Скрытый, 1/2", 9V без крышки

09512

Concealed, 1/2", 230 V without cover plate
Unterputz, 1/2", 230 V ohne Abdeckplatte
Скрытый, 1/2", 230 V без крышки



Fresh e61

Covering plate with sensor

Abdeckplatte mit Sensor

Крышка с сенсором

Drawing: p. 117



12261

e61

Covering plate with sensor for
products 09511 and 09512.
ABS, white

Abdeckplatte mit Sensor für
Produkte 09511 und 09512.
ABS, weiß

Крышка с сенсором для
артикулов 09511 и 09512.
ABS, белый



Fresh e63

Covering plate with sensor

Abdeckplatte mit Sensor

Крышка с сенсором

Drawing: p. 117



12263

e63

Covering plate with sensor for
products 09511 i 09512.
ABS, chrome-matt

Abdeckplatte mit Sensor für
Produkte 09511 und 09512.
ABS, Chrom-matt

Крышка с сенсором для
артикулов 09511 и 09512.
ABS, белый



Sensor mixers

Sensorarmaturen
Сенсорные смесители

Fresh



e12

FRESH IR for cold or preset water;
battery powering 6V/230V

FRESH IR für kaltes oder
voreingestelltes Wasser;
Batteriestromversorgung 6V/230V

Изделия FRESH IR – холодная вода
или заданная температура; питание
от батарейки 6V/230V



e70

Sensor urinal flusher; battery
powering 6V

Urinal Sensorspüler;
Batteriestromversorgung 6V

Сенсорный смыватель для
писсуара, питание от батарейки 6V



e60

Concealed sensor urinal flusher;
powering 6V/220V

Unterputz - Urinal Sensorspüler;
Stromversorgung 6V/220V

Скрытый сенсорный смыватель для
писсуара, питание 6V/220V

Fresh e12

Sensor basin mixer
Sensor-Waschbeckenarmatur
Сенсорный смеситель для
умывальника

Drawing: p. 117



09013 09011

Fresh e60

Concealed urinal sensor flusher
Unterputz - Urinal Sensorspüler
Скрытый сенсорный смыватель
для писсуара

Drawing: p. 117



09508 09502

Fresh e70

Urinal sensor flusher/battery
version
Urinal Sensorspüler /
Batterieversion
Сенсорный смыватель
для писсуара / версия с
батарейкой

Drawing: p. 117



09501



e40



Fresh e40

Elektronska armatura za prho
Elektronska armatura za tuš

Drawing: p. 117



09402 09401

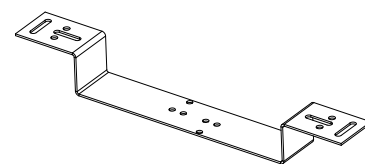
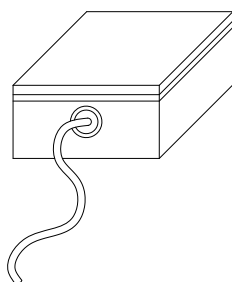
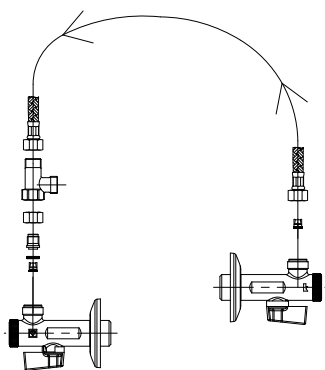

12704

Premixing set
Vormischset

Пред.микс комплект

Note: for articles
09016, 09017, 09020, 09021

Bemerkung: für Artikel
09016, 09017, 09020, 09021

Примечание: для артикулов
09016, 09017, 09020, 09021

12705

Powering set FRESH IR
Stromversorgungsset FRESH IR
Комплект питания FRESH IR

12706

Installation set
Einbauset
Монтажный комплект



classic *series*

Kitchen &

bathroom

Sanitary kitchen mixers

Sanitärarmaturen für Küche

Смесители для кухни

Prestige

p20



Prestige p20

Sanitary kitchen mixer
Sanitär-Küchenarmatur
Кухонный смеситель

Drawing: p. 118



00151 01132



Ceramic cartridge enables the mechanical limitation or setting of water temperature, two-level opening on the other hand helps to limit your water consumption.

Keramikkartusche ermöglicht die mechanische Begrenzung oder Einstellung der Wassertemperatur, zweistufige Öffnung auf der anderen Seite hilft Ihren Wasserverbrauch zu begrenzen.

Керамический картридж позволяет установить механические ограничения или настроить температуру воды, двух-уровневое открытие помогает ограничить расхода воды.





Prestige p21

Sanitary wall kitchen mixer
 Sanitäre Wandküchenarmatur
 Кухонный смеситель
 настенный
 Drawing: p. 118



00252 00251

 angle valves
 Eckventile
 Угловые вентили

 only mixers
 nur Armatur
 Только смеситель

 low pressure version
 Niederdruckversion
 версия низкого давления



p21

Bathroom mixers

Badarmaturen
Смесители для ванной

Prestige





Ceramic cartridge enables the mechanical limitation or setting of water temperature, two-level opening on the other hand helps to limit your water consumption.

Keramikkartusche ermöglicht die mechanische Begrenzung oder Einstellung der Wassertemperatur, zweistufige Öffnung auf der anderen Seite hilft Ihren Wasserverbrauch zu begrenzen.

Керамический картридж позволяет установить механические ограничения или настроить температуру воды, двух-уровневое открытие помогает ограничить расхода воды.



p10



p11



p50

Prestige p10

Basin mixer
Waschbeckenarmatur
Смеситель для умывальника

Drawing: p. 117



00061 00071 00051

Prestige p11

Basin mixer
Waschbeckenarmatur
Смеситель для умывальника

Drawing: p. 117, 118



00063 00073 00055

Prestige p50

Bidet mixer
Bidetarmatur
Смеситель для биде

Drawing: p. 118



00561 00571 00551



with waste
Abfall
Со стоком



angle valves
Eckventile
Угловые вентили



with waste, siphon, angle valves
Abfall, Siphon, Eckventile.
Сток, сифон, угловые вентили



only mixers
nur Armatur
Только смеситель



low pressure version
Niederdruckversion
ерсия низкого давления

Bathroom mixers

Badarmaturen
Смесители для ванной

Prestige





p30



Prestige p30

Bath/shower mixer
Wannen-/Duscharmatur
Смеситель для ванны/душа

Drawing: p. 118



00353 00356 00352



Ceramic cartridge enables the mechanical limitation or setting of water temperature, two-level opening on the other hand helps to limit your water consumption.

Keramikkartusche ermöglicht die mechanische Begrenzung oder Einstellung der Wassertemperatur, zweistufige Öffnung auf der anderen Seite hilft Ihren Wasserverbrauch zu begrenzen.

Keramička kartuša omogućava mehaničko ograničenje, odnosno podešavanje temperature. Keramički kartridž omogućuje postaviti mehaničke ograničenja ili postaviti temperaturu vode, dvuh-uravnevoe otvorenje pomaže ograničiti raschoda vody.

p40



Prestige p40

Shower mixer
Duscharmatur
Смеситель для душа

Drawing: p. 118



00452 00455 00451

 only mixers
nur Armatur
Только смеситель

 shower head
Brausekopf,
Насадка душа

 Shower head, hose and shower rail
Brausekopf, Brauseschlauch und Brausestange
Насадка, шланг и рейлинг для душа

Sanitary kitchen mixers

Sanitärarmaturen für Küche

Смесители для кухни

Harmony



h21

Harmony h21

Sanitary wall kitchen mixer

Sanitäre Wandküchenarmatur

Кухонный смеситель

настенный

Drawing: p. 125



00292 00291



Bathroom mixers

Badarmaturen
Смесители для ванной

Harmony



h10

Harmony h10

Basin mixer
Waschbeckenarmatur
Смеситель для умывальника

Drawing: p. 125





h40



h30

h50



Harmony h30

Bath/shower mixer
Wannen-/Duscharmatur
Смеситель для ванны/душа

Drawing: p. 125



00395 00393 00394



with waste
Abfall
Со стоком



with waste, siphon, angle valves
Abfall, Siphon, Eckventile.
Сток, сифон, угловые вентили



low pressure version
Niederdruckversion
версия низкого давления



shower head
Brausekopf,
Насадка душа



Shower head, hose and shower rail
Brausekopf, Brauseschlauch und Brausestange
Насадка, шланг и рейлинг для душа

Harmony h50

Bidet mixer
Bidetarmatur
Смеситель для биде

Drawing: p. 125, 126



00594 00592 00591

Harmony h40

Shower mixer
Duscharmatur
Смеситель для душа

Drawing: p. 125



00493 00491 00492

Sanitary kitchen mixers

Sanitärarmaturen für Küche
Смесители для кухни

Project



m20

Project m20

Sanitary kitchen mixer
Sanitär-Küchenarmatur
Кухонный смеситель

Drawing: p. 121



00185 00184 01185



angle valves
Eckventile
Угловые вентили



only mixers
nur Armatur
Только смеситель



low pressure version
Niederdruckversion
ерсия низкого давления



Bathroom mixers

Badarmaturen
Смесители для ванной

Project



m-a1



m50



m10

Project m-a1

Base for basin mixer
Sockel für Waschbeckenarmatur
База для смесителя для
умывальника
Drawing: p. 115



19228

Project m10

Basin mixer
Waschbeckenarmatur
Смеситель для умывальника

Drawing: p. 121



00026 00024 00025 00023

Project m50

Bidet mixer
Bidetarmatur
Смеситель для биде

Drawing: p. 121



00518 00516 00515



with waste
Abfall
Со стоком



with waste, siphon, angle valves
Abfall, Siphon, Eckventile.
Сток, сифон, угловые вентили



low pressure version
Niederdruckversion
ерсия низкого давления



m30



Project m30

Bath/shower mixer
Wannen-/Duscharmatur
Смеситель для ванны/душа

Drawing: p. 121



00326 00325



m40

Project m40

Shower mixer
Duscharmatur
Смеситель для душа

Drawing: p. 121



00427 00425

Sanitary kitchen mixers

Sanitärarmaturen für Küche
Смесители для кухни

Simpaty



S20

S30

S40



Simpaty s20

Sanitary kitchen mixer
 Sanitär-Küchenarmatur
 Кухонный смеситель

Drawing: p. 119



00186 00182 01182

 angle valves
 Eckventile
 Угловые вентили

 only mixers
 nur Armatur
 Только смеситель

 low pressure version
 Niederdruckversion
 версия низкого давления

Simpaty s40

Sanitary kitchen mixer
 Sanitär-Küchenarmatur
 Кухонный смеситель

Drawing: p. 120



00190 00193 01187 01186

Simpaty s30

Sanitary kitchen mixer
 Sanitär-Küchenarmatur
 Кухонный смеситель

Drawing: p. 119



00188 00189 01189 01188

Sanitary kitchen mixers

Sanitärarmaturen für Küche

Смесители для кухни

Simpaty

S21



Simpaty s21

Sanitary kitchen mixer
Sanitär-Küchenarmatur
Кухонный смеситель

Drawing: p. 119



00183 00181 01181



S24



S23



S22

Simpaty s22

Sanitary wall kitchen mixer
Sanitäre Wandküchenarmatur
Кухонный смеситель
настенный
Drawing: p. 119



00282 00281



only mixers
nur Armatur
Только смеситель



low pressure version
Niederdruckversion
ерсия низкого давления

Simpaty s24

Basin mixer – for hospitals
Waschbeckenarmatur – für
Krankenhäuser
Смесители для умывальника –
для больниц
Drawing: p. 119



00237

Simpaty s23

Sanitary wall kitchen mixer
Sanitäre Wandküchenarmatur
Кухонный смеситель
настенный
Drawing: p. 119



01281

Bathroom mixers

Badarmaturen
Смесители для ванной

Simpaty



s10



s50

s39



Simpaty s10

Basin mixer
Waschbeckenarmatur
Смеситель для умывальника

Drawing: p. 118, 119



00084 00082 00083 00081 01081

Simpaty s39

Shower mixer
Duscharmatur
Смеситель для душа

Drawing: p. 120



00480 00481 00482

Simpaty s50

Bidet mixer
Bidetarmatur
Смеситель для биде

Drawing: p. 120



00584 00582 00581



S41

Simpaty s41

Mixer for sink and bath
Mischer für Waschbecken und
Badewanne

Смеситель для мойки и ванны
Drawing: p. 120



00383



with waste
Abfall
Со стоком



with waste, siphon, angle valves
Abfall, Siphon, Eckventile.
Сток, сифон, угловые вентили



shower head
Brausekopf,
Насадка душа



Shower head, hose and shower rail
Brausekopf, Brauseschlauch und Brausestange
Насадка, шланг и рейлинг для душа

Bathroom mixers

Badarmaturen
Смесители для ванной

Simpaty



S32



S31

Simpaty s32

Bath/shower mixer
Wannen-/Duscharmatur
Смеситель для ванны/душа

Drawing: p. 120



00380 00381 00384





Simpaty s31

Bath/shower mixer
Wannen-/Duscharmatur
Смеситель для ванны/душа

Drawing: p. 120



00388 00389

-  angle valves
Eckventile
Угловые вентили
-  only mixers
nur Armatur
Только смеситель
-  visokotlačna izvedba
visokotlačna izvedba
-  shower head
Brausekopf,
Насадка душа
-  Shower head, hose and shower rail
Brausekopf, Brauseschlauch und Brausestange
Насадка, шланг и рейлинг для душа



S42

This model is fitted for high pressure boilers.
Shower head is included.

Dieses Modell ist für Hochdruckboilers ausgestattet; der Brausekopf ist im Lieferumfang enthalten.

Данная модель предназначена для бойлеров высокого давления; включена душевая насадка.

Simpaty s42

Bath/shower mixer
Wannen-/Duscharmatur
Смеситель для ванны/душа

Drawing: p. 120



01381

All sanitary mixers in range SIMPATY could be provided also with the handle for hospitals.

Alle Sanitärarmaturen der Palette SIMPATY sind auch mit dem Griff für Krankenhäuser erhältlich.

Все смесители в серии SIMPATY могут также поставляться с ручкой для больниц.



S51

Simpaty s51

Basin mixer – for hospitals
Waschbeckenarmatur – für Krankenhäuser
Drawing: p. 120



00037

Sanitary kitchen mixers

Sanitärarmaturen für Küche
Смесители для кухни

Stil

Z20



Z400



Stil z20

Sanitary kitchen mixer
Sanitär-Küchenarmatur
Кухонный смеситель

Drawing: p. 122



07169 07158 08150

Z22



Stil z22

Sanitary kitchen mixer
Sanitär-Küchenarmatur
Кухонный смеситель

Drawing: p. 122



07163 07159 08161 01164

Stil z400

Sanitary kitchen mixer
Sanitär-Küchenarmatur
Кухонный смеситель

Drawing: p. 123



08266



angle valves
Eckventile
Угловые вентили



only mixers
nur Armatur
Только смеситель



low pressure version
Niederdruckversion
ерсия низкого давления



Stil z40

Sanitary kitchen mixer
Sanitär-Küchenarmatur
Кухонный смеситель

Drawing: p. 122



07162 07156 08149

z40



Stil z42

Sanitary kitchen mixer
Sanitär-Küchenarmatur
Кухонный смеситель

Drawing: p. 122



07165 07157 08163

z42

Stil z200

Sanitary kitchen mixer
Sanitär-Küchenarmatur
Кухонный смеситель

Drawing: p. 123



08255



Sanitary kitchen mixers

Sanitärarmaturen für Küche

Смесители для кухни

Stil



Z25



Z27

Z26



Stil z25

Sanitary kitchen mixer
Sanitär-Küchenarmatur
Кухонный смеситель

Drawing: p. 122



07263

Stil z26

Sanitary kitchen mixer
Sanitär-Küchenarmatur
Кухонный смеситель

Drawing: p. 122



07264

Stil z27

Sanitary kitchen mixer
Sanitär-Küchenarmatur
Кухонный смеситель

Drawing: p. 122



07265



Z45

Z47



Z46



Stil z45

Sanitary kitchen mixer
Sanitär-Küchenarmatur
Кухонный смеситель

Drawing: p. 122



07260



only mixers
nur Armatur
Только смеситель

Stil z47

Sanitary kitchen mixer
Sanitär-Küchenarmatur
Кухонный смеситель

Drawing: p. 122



07262

Stil z46

Sanitary kitchen mixer
Sanitär-Küchenarmatur
Кухонный смеситель

Drawing: p. 122



07261

Bathroom mixers

Badarmaturen
Смесители для ванной

Stil



Z10

STIL sanitary mixers

An interesting interlacement of classical forms and vintage, retro lines is associated with beautiful details in chrome or gold. Giving your home a touch of tradition and homeliness

STIL Sanitärarmaturen

Eine interessante Verflechtung der klassischen Formen und traditionellen, retro Linien ist mit schönen Details in Chrom oder Gold verbunden.

Geben Sie Ihrem Zuhause einen Hauch von Tradition und Gemütlichkeit.

Смесители STIL

Интересное переплетение классических форм и ретро-линий ассоциируется с красивыми деталями в цвете хрома или золота. Добавит вашему дому ощущение традиций и домашнего уюта.



Z12

Stil z10

Basin mixer
Waschbeckenarmatur
Смеситель для умывальника

Drawing: p. 121



07066 07072 07061

Stil z12

Basin mixer
Waschbeckenarmatur
Смеситель для умывальника

Drawing: p. 122



07067 07077 07062

-  with waste
Abfall
Со стоком
-  angle valves
Eckventile
Угловые вентили
-  with waste, siphon, angle valves
Abfall, Siphon, Eckventile.
Сток, сифон, угловые вентили
-  only mixers
nur Armatur
Только смеситель
-  low pressure version
Niederdruckversion
ерсия низкого давления



Z13



Z11



Stil z11

Basin mixer
Waschbeckenarmatur
Смеситель для умывальника

Drawing: p. 121



07068 07073 07063

Stil z13

Basin mixer
Waschbeckenarmatur
Смеситель для умывальника

Drawing: p. 122



07078 07079 07064

Bathroom mixers

Badarmaturen
Смесители для ванной

Stil



Z50



Z40



Z30

Stil z30

Bath/shower mixer
Wannen-/Duscharmatur
Смеситель для ванны/душа

Drawing: p. 122



07357

Stil z40

Shower mixer
Duscharmatur
Смеситель для душа

Drawing: p. 122



07465 07462

Stil z50

Bidet mixer
Bidetarmatur
Смеситель для биде

Drawing: p. 122, 123



07558 07554



Z51



Z31

Z41



Stil z31

Bath/shower mixer
Wannen-/Duscharmatur
Смеситель для ванны/душа

Drawing: p. 122



07358



with waste
Abfall
Со стоком



with waste, siphon, angle valves
Abfall, Siphon, Eckventile.
Сток, сифон, угловые вентили



only mixers
nur Armatur
Только смеситель



shower head
Brausekopf,
Насадка душа



Shower head, hose and shower rail
Brausekopf, Brauseschlauch und Brausestange
Насадка, шланг и рейлинг для душа

Stil z51

Bidet mixer
Bidetarmatur
Смеситель для биде

Drawing: p. 122, 123



07559 07555

Stil z41

Shower mixer
Duscharmatur
Смеситель для душа

Drawing: p. 122



07466 07464

Sanitary kitchen mixers

Sanitärarmaturen für Küche

Смесители для кухни

Classic



Classic c20

Sanitary kitchen mixer
Sanitär-Küchenarmatur
Кухонный смеситель

Drawing: p. 124



05154 06156 06158

Classic c21

Sanitary kitchen mixer
Sanitär-Küchenarmatur
Кухонный смеситель

Drawing: p. 124



05251



angle valves
Eckventile
Угловые вентили



only mixers
nur Armatur
Только смеситель



low pressure version
Niederdruckversion
версия низкого давления



C22

C23



C24

Classic c22

Sanitary kitchen mixer
Sanitär-Küchenarmatur
Кухонный смеситель

Drawing: p. 124



05252

Classic c23

Sanitary kitchen mixer
Sanitär-Küchenarmatur
Кухонный смеситель

Drawing: p. 124



05253

Classic c24

Sanitary kitchen mixer
Sanitär-Küchenarmatur
Кухонный смеситель

Drawing: p. 124



06251

Bathroom mixers

Badarmaturen
Смесители для ванной

Classic

Classic c10

Basin mixer
Waschbeckenarmatur
Смеситель для умывальника

Drawing: p. 123



c10

c06



Classic c04

Basin mixer
Waschbeckenarmatur
Смеситель для умывальника

Drawing: p. 123



c07



c05



Classic c05

Basin mixer
Waschbeckenarmatur
Смеситель для умывальника

Drawing: p. 123



c04



Classic c06

Basin mixer
Waschbeckenarmatur
Смеситель для умывальника

Drawing: p. 123



Classic c07

Basin mixer
Waschbeckenarmatur
Смеситель для умывальника

Drawing: p. 123



with waste
Abfall
Со стоком



angle valves
Eckventile
Угловые вентили



with waste, siphon, angle valves
Abfall, Siphon, Eckventile.
Сток, сифон, угловые вентили



only mixers
nur Armatur
Только смеситель



low pressure version
Niederdruckversion
ерсия низкого давления



C11



C01



C08



C02

C50



C15



Classic c11

Basin mixer
Waschbeckenarmatur
Смеситель для умывальника

Drawing: p. 123



10651

Classic c50

Bidet mixer
Bidetarmatur
Смеситель для биде

Drawing: p. 124, 125



05554 05557 05553

Classic c01

Basin mixer
Waschbeckenarmatur
Смеситель для умывальника

Drawing: p. 123



10052

Classic c02

Basin mixer
Waschbeckenarmatur
Смеситель для умывальника

Drawing: p. 123



10151

Classic c15

Basin mixer
Waschbeckenarmatur
Смеситель для умывальника

Drawing: p. 123



10551

Classic c08

Basin mixer
Waschbeckenarmatur
Смеситель для умывальника

Drawing: p. 123



10355

Bathroom mixers

Badarmaturen
Смесители для ванной

Classic



c30



c31

Classic c30

Bath/shower mixer
Wannen-/Duscharmatur
Смеситель для ванны/душа

Drawing: p. 124



05351



c12

Classic c31

Mixer for sink and bath
Mischer für Waschbecken und
Badewanne

Смеситель для мойки и ванны

Drawing: p. 124



05355



c43

Classic c43

Pipa zidna - prha ročna
Slavina zidna - ručni tuš

Drawing: p. 124



10451

Classic c12

Basin mixer
Waschbeckenarmatur
Смеситель для умывальника

Drawing: p. 123



10652



with waste
Abfall
Со стоком



angle valves
Eckventile
Угловые вентили



with waste, siphon, angle valves
Abfall, Siphon, Eckventile.
Сток, сифон, угловые вентили



only mixers
nur Armatur
Только смеситель



shower head
Brausekopf,
Насадка душа

C40

C09



C03



Classic c40

Shower mixer
Duscharmatur
Смеситель для душа

Drawing: p. 124



05452 05451



Classic c41

Shower mixer
Duscharmatur
Смеситель для душа

Drawing: p. 124



05454

Classic c42

Bath/shower mixer
Wannen-/Duscharmatur
Смеситель для ванны/душа

Drawing: p. 124



05455

C41

C42

C44

Classic c09

Pipa zidna - ventil
Slavina zidna - ventil

Drawing: p. 123



10356

Classic c03

Pipa zidna - priključek
Slavina zidna - priključek

opomba: za pralni ali pomivalni stroj 3/4"
bilješka: za perilico rublja ili posuđa 3/4"

Drawing: p. 123



10152

Classic c44

Pipa zidna - prha stoječa
Slavina zidna - stojeći tuš

Drawing: p. 124



10452





Series
design
Showers

Shower heads

Shower heads
Насадка душа

Showers

Pure a01

Shower head
Brausekopf
Насадка душа

Drawing: p. 126



12050

Thin a02

Shower head
Brausekopf
Насадка душа

Drawing: p. 126



12051

Smart a03

Shower head
Brausekopf
Насадка душа

Drawing: p. 126



12052

Smart a03w

Shower head - White
Brausekopf weiß
Насадка для душа, белая

Drawing: p. 127



12053



a01

a02



a03

a03w



a04

Infinity a33

Wall shower holder
Duschsatz mit Wandhalterung
Комплект для душа с
настенным кронштейном
Drawing: p. 129



12352

Infinity a04

Shower head
Brausekopf
Насадка душа

Drawing: p. 126



12043



a33

Shower sets

Duschsätze
Комплекты для душа

Showers



a05



a34

Infinity a05

Shower set with shower rail
Duschsatz mit Brausestange
Комплект для душа с
рейлингом
Drawing: p. 126



12460

Project a34

Shower set with shower rail
Duschsatz mit Brausestange
Комплект для душа с
рейлингом
Drawing: p. 126



12451



a06



a07



Pure S a06

Shower set with shower rail
Duschsatz mit Brausestange
Комплект для душа с
рейлингом
Drawing: p. 126



12461

Smart a07

Shower set with shower rail
Duschsatz mit Brausestange
Комплект для душа с
рейлингом
Drawing: p. 126



12462

Shower sets

Duschsätze
Комплекты для душа

Showers

a11

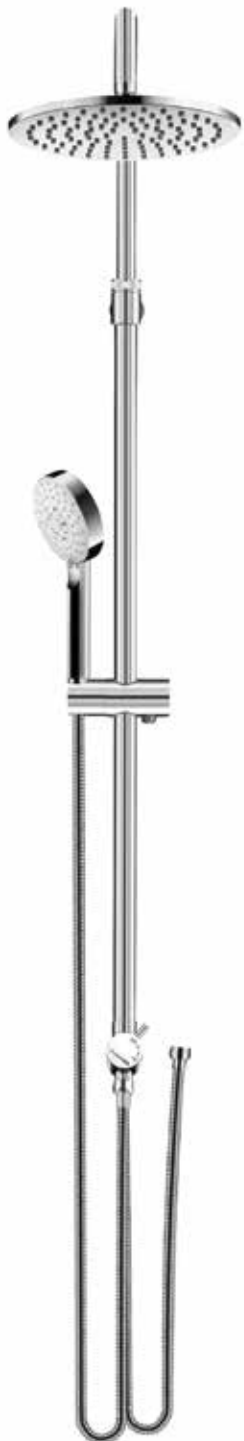

a12

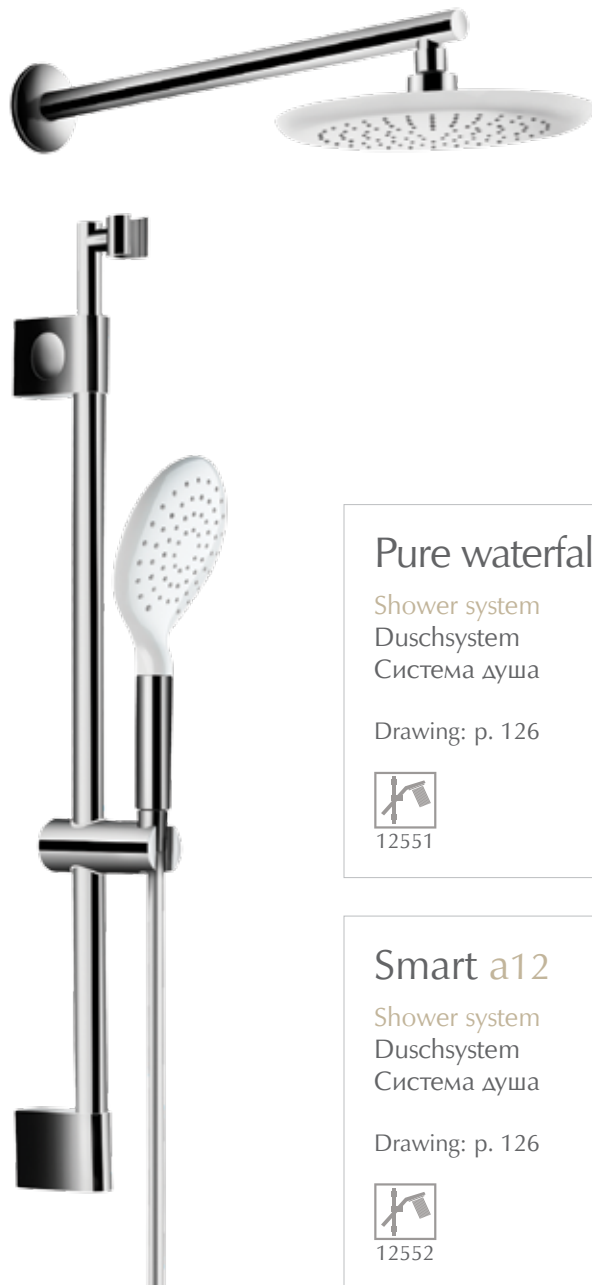

Pure waterfall a11

Shower system
Duschsystem
Система душа

Drawing: p. 126



12551

Smart a12

Shower system
Duschsystem
Система душа

Drawing: p. 126



12552



Head shower

Kopfbrause
Надголовный душ

Showers

Head shower a08

Kopfbrause
Надголовный душ
Φ 227 mm, ABS

Drawing: p. 126



12103

a08



Head shower a08w

Head shower - white
Kopfbrause, weiss
Надголовный душ, белая
Φ 227 mm, ABS
Drawing: p. 129



12107

a08w



Head shower a09

Kopfbrause
Надголовный душ

260 x 200 mm, ABS
Drawing: p. 126



12106

a09



Head shower a10

Kopfbrause
Надголовный душ
Φ 200 mm, Brass / Messing / Латунь

Drawing: p. 126



12104

a10



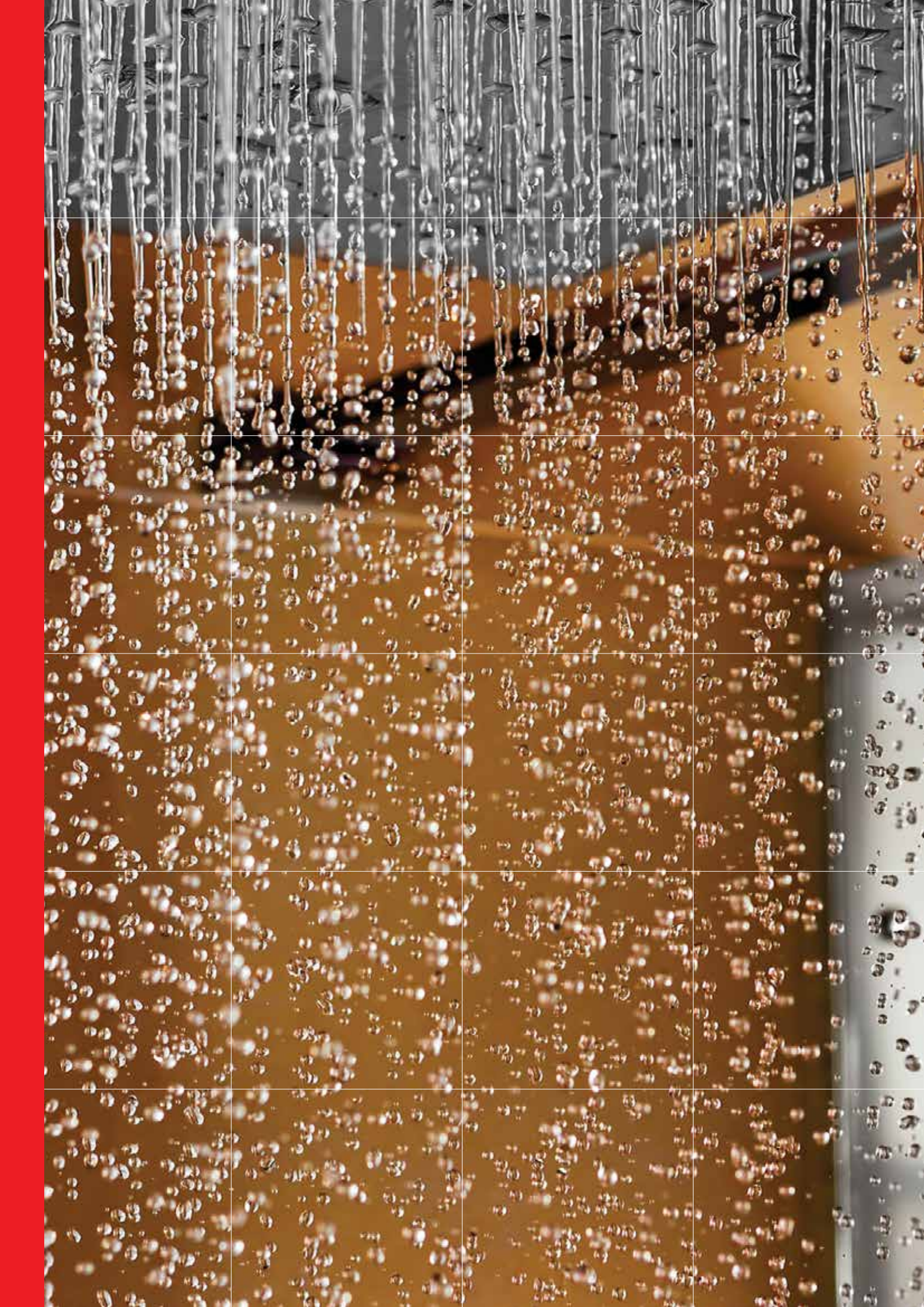

Shower sets

Duschsätze
Комплекты для душа

Showers

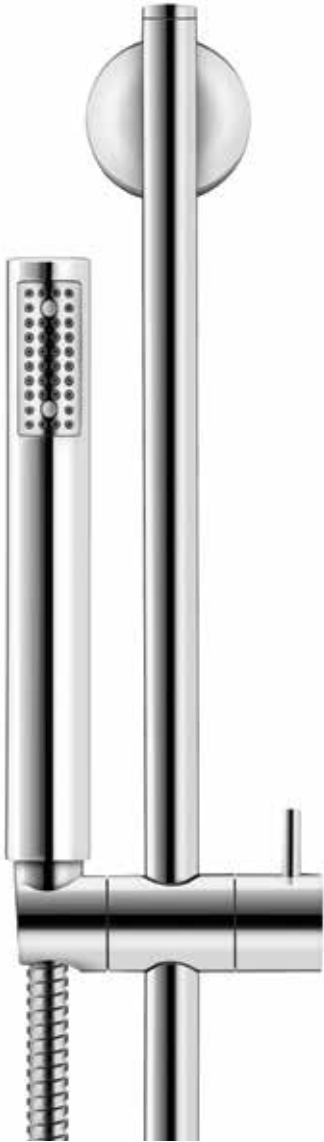

Fresh a13

Shower set with shower rail
Duschsatz mit Brausestange
Комплект для душа с
рейлингом
Drawing: p. 126



12452



Fresh a14

Wall shower holder
Duschsatz mit Wandhalterung
Комплект для душа с
настенным кронштейном
Drawing: p. 129



12357



Fresh a15

Shower heads
Brausekopf
Насадка душа

Drawing: p. 129



12047

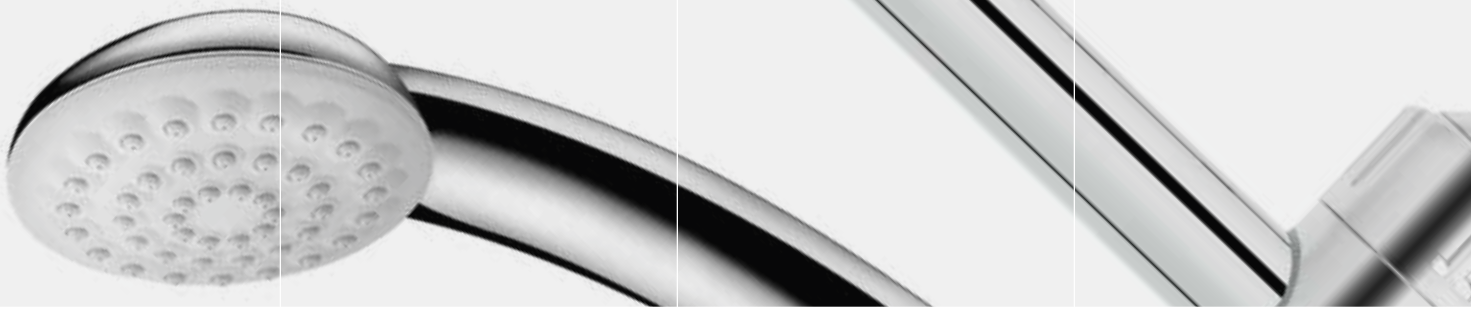

Prestige a17

Wall shower holder
 Duschsatz mit Wandhalterung
 Комплект для душа с
 настенным кронштейном
 Drawing: p. 129



12351



Prestige a18

Shower heads
 Brausekopf
 Насадка душа

Drawing: p. 129



12044

Simpaty a20

Wall shower holder
 Duschsatz mit Wandhalterung
 Комплект для душа с
 настенным кронштейном
 Drawing: p. 129



12358



Simpaty a21

Shower heads
 Brausekopf
 Насадка душа

Drawing: p. 129



12042

Project a23

Wall shower holder
 Duschsatz mit Wandhalterung
 Комплект для душа с
 настенным кронштейном
 Drawing: p. 126



12354



Project a24

Shower heads
 Brausekopf
 Насадка душа

Drawing: p. 129



12041

Shower sets

Duschsätze
Комплекты для душа

Showers

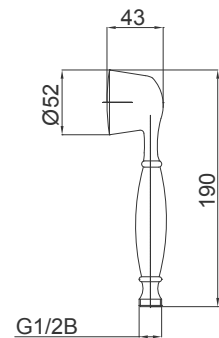

Stil 12455, 12456

Shower set with shower rail
Duschsatz mit Brausestange
Комплект для душа с
рейлингом
Drawing: p. 127



12455 12456

Stil 12355, 12356

Wall shower holder
Duschsatz mit Wandhalterung
Комплект для душа с
настенным кронштейном
Drawing: p. 127



12355 12356

Stil 12045, 12046

Shower heads
Brausekopf
Насадка душа



12045 12046

12655

Shower rail
Brausestange
Рейлинг для душа

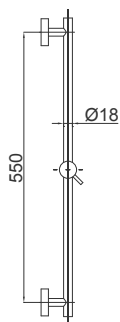

12655

12651

Shower rail
Brausestange
Рейлинг
для душа

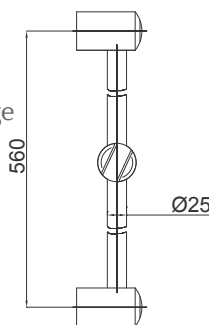

12651

12652

Shower rail
Brausestange
Рейлинг
для душа

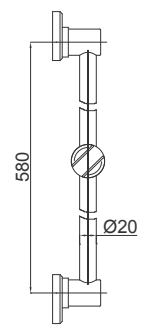

12652

12154, 12155

Wall shower holder
Wandhalterung
Настенный держатель душа

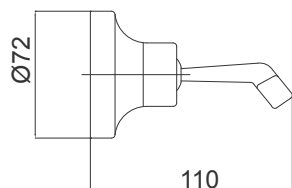

12154 12155

12653, 12654

Shower rail
Brausestange
Рейлинг
для душа

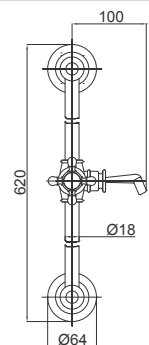

12653 12654



12001

Shower hose
Сријево за туш
Шланг душа

Drawing: p. 128



12001



Pure Glossy 12002

Tuš cev Rock&Roll
Brauseschlauch Rock & Roll
Шланг душа Rock & Roll

Drawing: p. 128



12002



12151

Wall shower holder
Wandbrausehalter
Настенный держатель душа

Drawing: p. 128



12151



Pure 12152

Wall shower holder
Wandbrausehalter
Настенный держатель душа

Drawing: p. 128



12152



Prestige 12153

Wall shower holder
Wandbrausehalter
Настенный держатель душа

Drawing: p. 128



12153





Series
design
Concealed
mixers

Concealed mixers

Unterputz - Armaturen
Скрытые смесители

Project Fresh Infinity

00367

Concealed shower mixer
Unterputz - Duscharmatur
Скрытый смеситель для душа

Note: entrance 2 x 1/2", exit 1 x 1/2", fitted casing only, for ø35 cartridge

Bemerkung: Eingang 2 x 1/2", Ausgang 1 x 1/2", nur Einbaugehäuse, für ø35 Kartusche

Примечание: вход 2 x 1/2", выход, только встраиваемый 1 x 1/2", для диаметра ø35

Drawing: p. 127

00368

Concealed bath/shower mixer
or mixer for two showers
Unterputz - Wannen/Duscharmatur
oder für zwei Duschen
Скрытый смеситель для
ванны/душа или скрытый
смеситель для двух душей

Note: entrance 2 x 1/2", exit 1 x 1/2", 1x 3/4" fitted casing only, for ø35 cartridge

Bemerkung: Eingang 2 x 1/2", Ausgang 1x 1/2", 1x 3/4" nur Einbaugehäuse, für ø35 Kartusche

Примечание: вход 2 x 1/2", выход, только встраиваемый 1 x 1/2", 1x 3/4" для диаметра ø35

Drawing: p. 127

00367



00368





Fresh 12259

Rosette and handle for concealed shower mixer

Sichtteil für Einhebelmischer Розетка и ручка для встраиваемого смесителя для душа

Drawing: p. 127



Project 12251

Rosette and handle for concealed shower mixer

Sichtteil für Einhebelmischer Розетка и ручка для встраиваемого смесителя для душа

Drawing: p. 127



Infinity 12249

Rosette and handle for concealed shower mixer

Sichtteil für Einhebelmischer Розетка и ручка для встраиваемого смесителя для душа

Drawing: p. 127



Fresh 12260

Rosette and handle for concealed mixer for the tub or 2 showers

Sichtteil für Einhebelmischer für die Wanne oder 2 Duschen Розетка и ручка для встраиваемого смесителя для ванны или душа

Drawing: p. 127



Project 12252

Rosette and handle for concealed mixer for the tub or 2 showers

Sichtteil für Einhebelmischer für die Wanne oder 2 Duschen Розетка и ручка для встраиваемого смесителя для ванны или душа

Drawing: p. 127



Infinity 12250

Rosette and handle for concealed mixer for the tub or 2 showers

Sichtteil für Einhebelmischer für die Wanne oder 2 Duschen Розетка и ручка для встраиваемого смесителя для ванны или душа

Drawing: p. 127

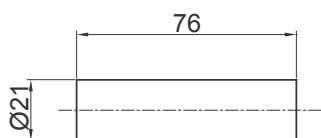

Universal 12701

Diverter extension

Verlängerung für Duschumschalter
Скрытая арматура отвода

Note: for 00368 and 00370

Bemerkung: für 00368 und 00370

Примечание: для артикулов 00368 и 00370

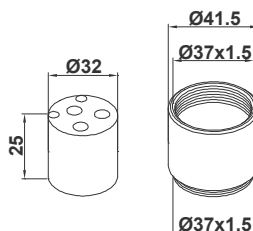

Universal 12703

Extension 25mm for mixer

Verlängerung 25mm für Armatur
Насадка 25 мм для скрытого смесителя

Note: for 00367 and 00368

bilješka: za artikle 00367 in 00368

Примечание: для артикулов 00368 и 00370



Infinity 12248

Rosette and handle for concealed shower mixer

Sichtteil für Einhebelmischer Розетка и ручка для встраиваемого смесителя для душа

Drawing: p. 129

Concealed mixers

Unterputz - Armaturen
Скрытые смесители

Prestige Simpaty Harmony

00369

Concealed shower mixer
Unterputz Mischbatterie
für die Dusche
встраиваемый настенный
смеситель для душа

Note: entrance 2 x 1/2", exit 1 x 1/2", fitted casing only, for fi 40 cartridge

Bemerkung: Eingang 2 x 1/2", Ausgang 1 x 1/2", nur Einbaugehäuse, für ø40 Kartusche

Примечание: вход 2 x 1/2", выход, только встраиваемый 1 x 1/2", для диаметра fi 40

Drawing: p. 129

00370

Concealed bathtub or two showers mixer
Unterputz Mischbatterie
für die Wanne oder 2
Duschen встраиваемый
настенный смеситель для
ванны или для душа

Note: entrance 2 x 1/2", exit 1 x 1/2", 1x 3/4" fitted casing only, for fi 40 cartridge

Bemerkung: Eingang 2 x 1/2", Ausgang 1 x 1/2", 1x 3/4" nur Einbaugehäuse, für ø40 Kartusche

Примечание: вход 2 x 1/2", выход, только встраиваемый 1 x 1/2", 1x 3/4" для диаметра fi 40

Drawing: p. 129

00369



00370

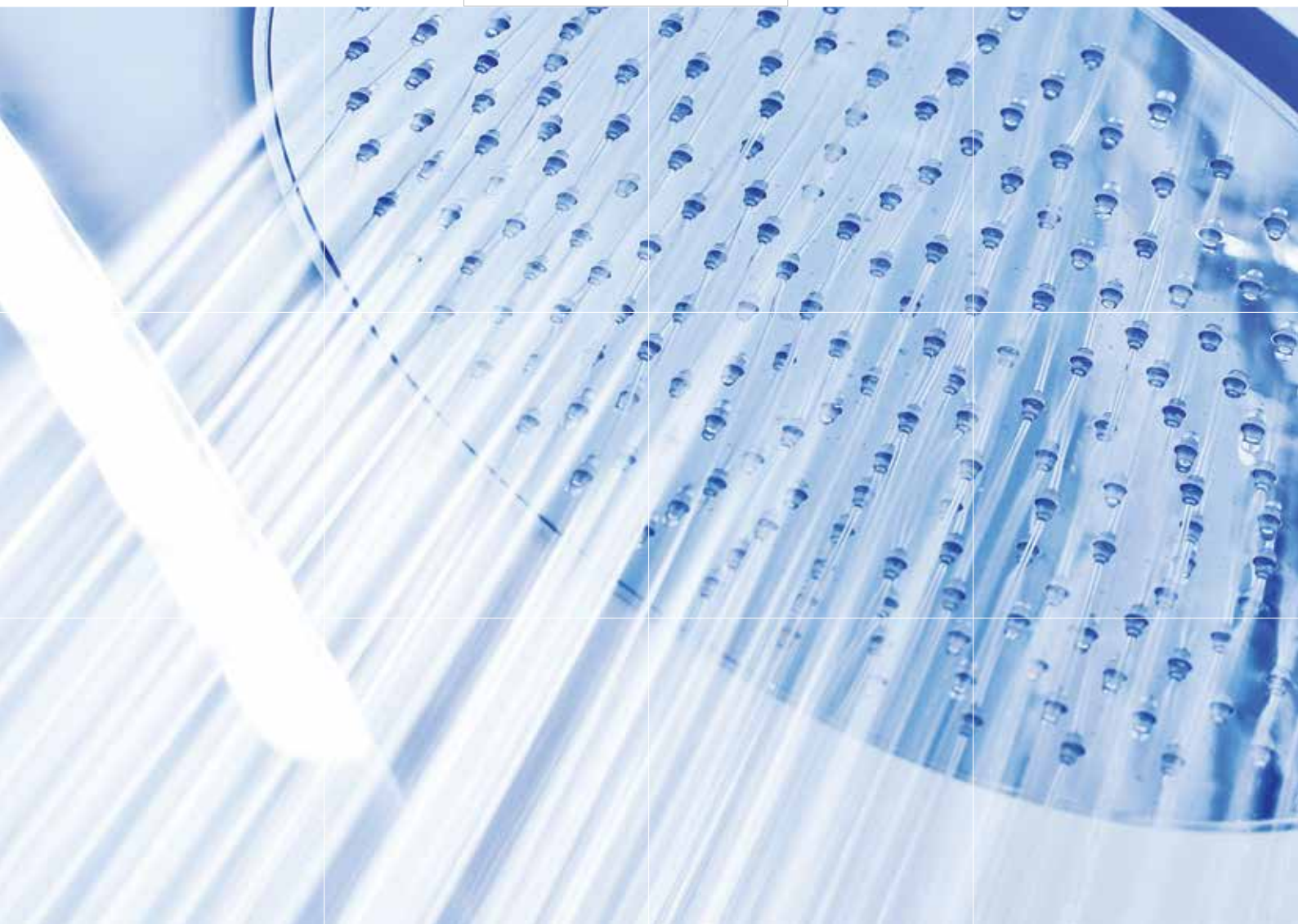



Prestige 12257

Rosette and handle for concealed shower mixer

Sichtteil für Einhebelmischer Розетка и ручка для встраиваемого смесителя для душа

Drawing: p. 127



Simpatty 12253

Rosette and handle for concealed shower mixer

Sichtteil für Einhebelmischer Розетка и ручка для встраиваемого смесителя для душа

Drawing: p. 127



Harmony 12255

Rosette and handle for concealed shower mixer

Sichtteil für Einhebelmischer Розетка и ручка для встраиваемого смесителя для душа

Drawing: p. 127



Prestige 12258

Rosette and handle for concealed mixer for the tub or 2 showers

Sichtteil für Einhebelmischer für die Wanne oder 2 Duschen Розетка и ручка для встраиваемого смесителя для ванны или душа

Drawing: p. 128



Simpatty 12254

Rosette and handle for concealed mixer for the tub or 2 showers

Sichtteil für Einhebelmischer für die Wanne oder 2 Duschen Розетка и ручка для встраиваемого смесителя для ванны или душа

Drawing: p. 127



Harmony 12256

Rosette and handle for concealed mixer for the tub or 2 showers

Sichtteil für Einhebelmischer für die Wanne oder 2 Duschen Розетка и ручка для встраиваемого смесителя для ванны или душа

Drawing: p. 127

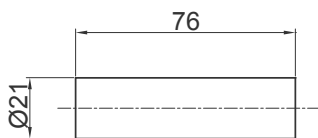

Universal 12701

Diverter extension

Verlängerung für Duschumschalter
Скрытая арматура отвода

Note: for 00368 and 00370

Bemerkung: für 00368 und 00370

Примечание: для артикулов 00368 и 00370

Extension 12702

Extension 25mm for mixer

Verlängerung 25mm für Armatur
Насадка 25 мм для скрытого смесителя

Note: for 00369 and 00370

bilješka: za artikle 00369 in 00370

Примечание: для артикулов 00369 и 00370

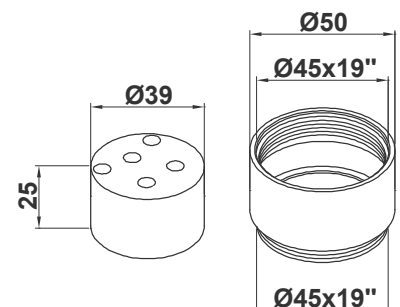

Concealed mixers

Unterputz - Armaturen
Скрытые смесители

Prestige Simpaty Harmony



Masiva 12101

Wall shower
Wandbrause
настенный монтаж

Drawing: p. 128



12101



Prestige 12201

Bath spout
Wannenauslauf
Излив для ванны

Drawing: p. 128



12201



Pure 12202

Bath spout
Wannenauslauf
Излив для ванны

Drawing: p. 128



12202



Pure 12207

Wall shower holder
Wandbrausehalter
Настенный держатель душа

Drawing: p. 128



12207



12209

Stropno držalo tuša
Stropni držač tuša

Drawing: p. 128



12209



Prestige 12102

Wall shower
Wandbrause
настенный монтаж

Drawing: p. 128



12102



Pure 12203

Wall shower connection 1/2"
Wandbrauseanschluss 1/2"
Арматура настенная 1/2"

Drawing: p. 128



12203



Prestige 12204

Wall shower connection
Wandbrauseanschluss
Арматура настенная

Drawing: p. 128



12204



Prestige 12206

Wall shower holder
Wandbrausehalter
Настенный держатель душа

Drawing: p. 128



12206



12208

Wall shower holder
Wandbrausehalter
Настенный держатель душа

Drawing: p. 128



12208



KANTDOOR

1 170 048

PBT 140mm

TEGEL 12.07

0.049

140mm

L 120.028

TEGEL ø 100mm

Rf 30

L 120.05

TEGEL 12.07

720mm x 1250

d.L. 120.031b

Zelfst. Rf30

d.L. 120.041

Rf30

96
95
94
93
92
91
90
89

432.24



Accessories

Valves

Ventile
Вентили

Valves



13108

Angle valve with filter G 1/2"
Eckventil mit Filter G 1/2"
Угловой вентиль с
фильтром G 1/2"



13104

Angle valve for
flushing G 1/2"
Eckventil für die
Spülung G 1/2"
Угловой вентиль
для смыва G 1/2"



13110

Angle valve G 1/2"
Eckventil G 1/2"
Угловой вентиль для G 1/2"



13109

Angle valve G 1/2"
Eckventil G 1/2"
Угловой вентиль для G 1/2"



13112

Angle valve for urinal G 1/2"
Eckventil für den Urinal G 1/2"
Угловой вентиль для
писсуара G 1/2"



13113

Angle ball valve with filter G 1/2"
Kugel Eckventil mit Filter G 1/2"
Угол шаровой клапан с
фильтром G 1/2"

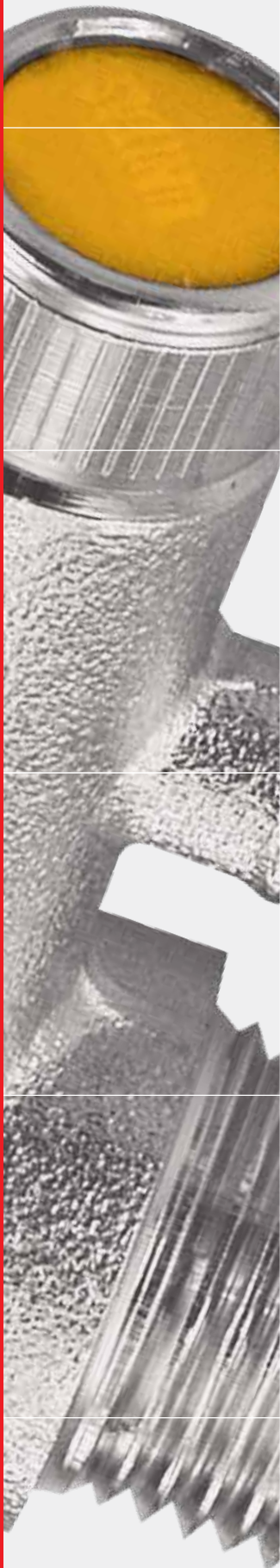

19412

Diverter G 1/2"
Umschalter G 1/2"
Отвод G 1/2"



19413

Diverter G 3/4"
Umschalter G 3/4"
Отвод G 1/2"



13001 1/2"
13002 3/4"

Safety valve 7 bars
Sicherheitsventil 7 bar
Защитный клапан /7 атм



13003 1/2"
13004 3/4"

Safety valve 10 bars
Sicherheitsventil 10 bar
Защитный клапан /10 атм

Valves

Ventile
Вентили

Valves



13301

Opening valve G 1/2"
Durchgangsventil G 1/2"
кран проходной G 1/2"



13401

Concealed valve G 1/2"
Unterputz-Ventil G 1/2"
Скрытый вентиль G 1/2"



2 4215 61

Closing valve G 1/2"
Absperrventil G 1/2"
Закрывающий вентиль G 1/2"



2 77665 4

Thermostatic mixing valve for
drinking water G 1/2"
Thermostatischer Mischventil
für Trinkwasser G 1/2"
Термостатический
смешивающий вентиль для
питьевой воды G 1/2"

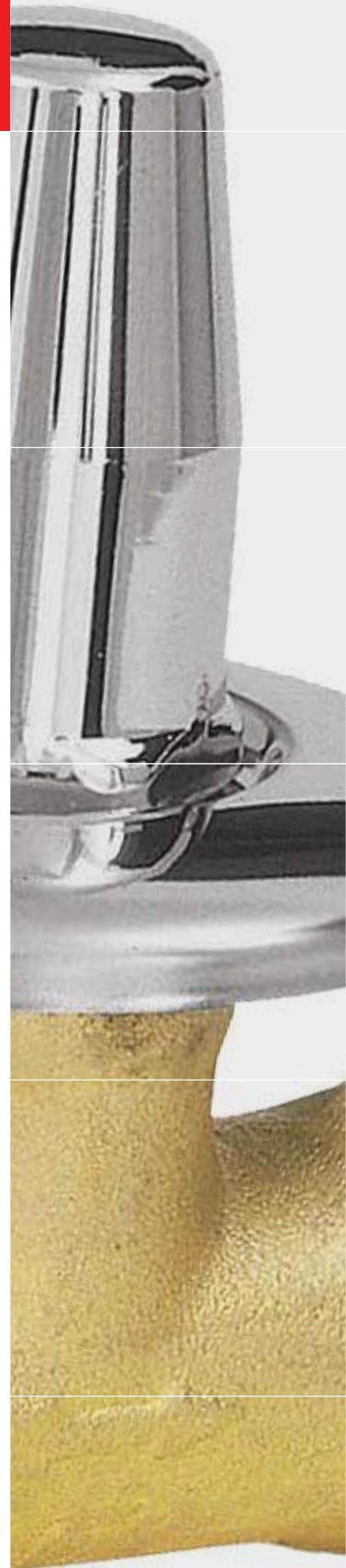

Siphons

Siphon
Сифоны

Siphons



16002

Draining valve G 1 1/4"
Entleerungsventil G 1 1/4"
Сливной вентиль G 1 1/4"



16001

Draining valve G 1 1/4"
Entleerungsventil G 1 1/4"
Сливной вентиль G 1 1/4"



16205

Draining valve with siphon
Entleerungsventil mit Siphon
Сливной вентиль с сифоном



16201

Siphon for basin G 1 1/4"
Siphon für Waschbecken
G 1 1/4"
Сифон для умывальника
G 1 1/4"



16204

Siphon for urinal
G 1 1/4"
Siphon für Urinal
G 1 1/4"
Сифон для писсуара
G 1 1/4"



16301

Siphon set for basin
G 1 1/4"
Siphon-Satz für Waschbecken
G 1 1/4"
Комплект сифона для
умывальника G 1 1/4"

Siphons

Siphon
Сифоны

Siphons



16206

Siphon for basin G 1 1/4"
Siphon für Waschbecken G
1 1/4"
Комплект сифона для
умывальника G 1 1/4"



16306

Siphon set for basin G 1 1/4"
Siphon-Satz für Waschbecken
G 1 1/4"
Комплект сифона для биде
G 1 1/4"



16202

Siphon for bidet
G 1 1/4"
Siphon für Bidet
G 1 1/4"
Комплект сифона
умывальника G 1/4"



16302

Siphon set for basin G 1 1/4"
Siphon-Satz für Waschbecken
G 1 1/4"
Комплект сифона для
умывальника G 1/4"



16305

Siphon set for bidet G 1 1/4"
Siphon-Satz für Bidet G 1
1/4"
Комплект сифона для биде
G 1 1/4"



16303

Siphon set for basin G 1 1/4"
Siphon-Satz für Waschbecken
G 1 1/4"
Комплект сифона для
умывальника G1 1/4"

16404

Draining/ filling set for
bathtub with siphon
Entleerungs-/Befüllungssatz
für Badewanne mit Siphon
Комплект наполнения/
слива для ванны с сифоном



16402

16404



16402

Draining/ filling set for
bathtub
Entleerungs-/Befüllungssatz
für Badewanne
Комплект наполнения/
слива для ванны

16401

Draining/ filling set for
bathtub
Entleerungs-/Befüllungssatz
für Badewanne
Комплект наполнения/
слива для ванны



16005



16401

16501

Siphon for washing machine
Siphon für Waschmaschine
Сифон для стиральной
машины

16005

Draining valve
Entleerungsventil
Сливной вентиль



16501

Accessories

Zubehör
аксессуары

Pribor



19001

Connection tubes
300/350 mm
Verbindungsschläuche
300/350 mm
Соединительные трубы
300/350 мм



19021

Connection tubes
fi 10x440
Verbindungsschläuche
fi 10x440
Соединительные трубы
fi 10x440



19022

Connection tubes
fi 10x422, nut 1/2"
Verbindungsschläuche
fi 10x422, nuss 1/2"
Соединительные трубы
fi 10x422, гайка 1/2"



19023

Connection tubes
fi 10x422, nut 3/8"
Verbindungsschläuche
fi 10x422, nuss 3/8"
Соединительные трубы
fi 10x422, гайка 3/8"



19011

Connection tubes
fi 360/400
Verbindungsschläuche
fi 360/400
Соединительные трубы fi
360/400



19133

Spout "S"
fi 13x300mm
Auslauf "S"
fi 13x300mm
Излив "S"
Ø13x300 мм

opomba: Note: Set includes 2 ECO aerators with water flow 6l/min and water flow regulator with water flow of 9 l/minute. It could be used at all ranges HERZ.

Bemerkung: Der Satz beinhaltet 2 ECO Belüfter mit einem Wasserdurchfluss von 6 l/min und einen Wasserdurchflussregler mit einem Wasserdurchfluss von 9 l/min. Er kann in allen HERZ Paletten verwendet werden.

Примечание: В набор входят 2 аэратора ECO с потоком воды 6 л/мин и регулятор потока на 9 л/мин. Можно использовать на всех сериях продукции HERZ



21001

Rosette 3/4"
Rosette 3/4"



19123

Set for water conservation
3-piece
Set zur Wassereinsparung
3-teilig
Набор для сохранения воды
3-х частей

19504

Reduction nut with seals
Reduziermutter mit Dichtung
Гайка с уплотнением

G1/2 - G3/4

21161

S- union with noise reduction
Auslaufrohr S mit Rauschunterdrückung
S-образный шумопонижающий
стык



19145

Spout "S"
fi 18x250mm
Auslauf "S"
fi 18x250mm
Излив "S"
fi 18x250mm

19123

Spout "S"
fi 13x200mm
Auslauf "S"
fi 13x200mm
Излив "S"
fi 13x200mm

19088

Shower head - white
Brausekopf - weiß
Насадка для душа - белая

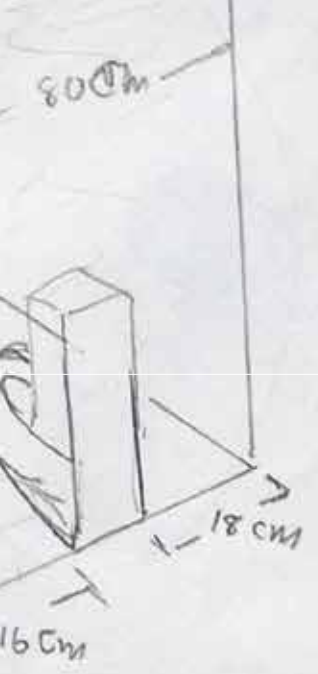

160cm

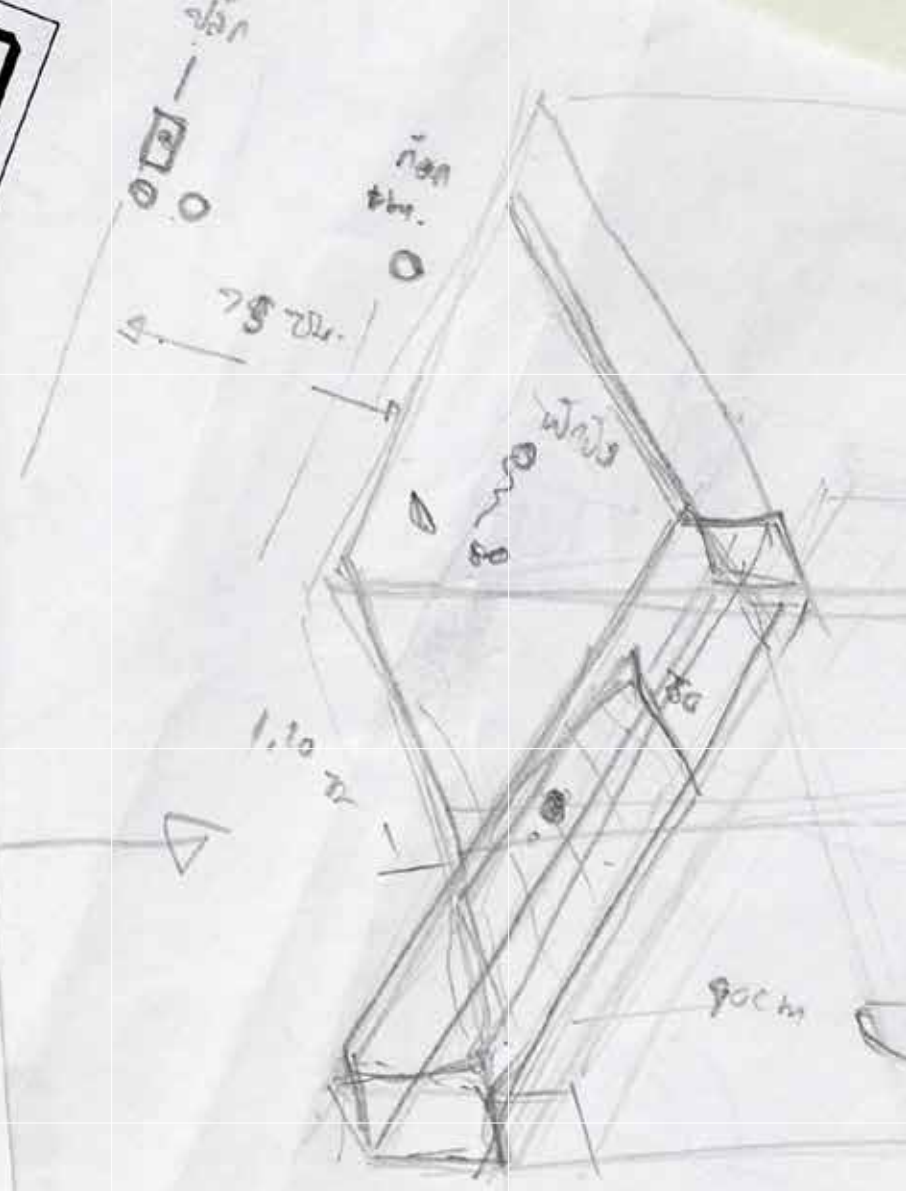

105



drawings

Kitchen &
bathroom

Infinity i10

Art. EAN pkg.
00001 3838963000013 6

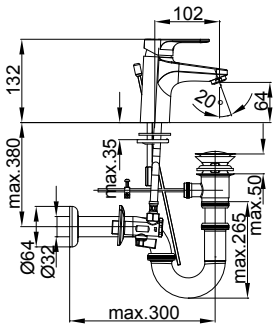

Infinity i10

Art. EAN pkg.
00002 3838963000020 8

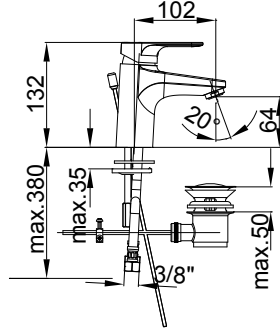

Infinity i10

Art. EAN pkg.
00003 3838963000037 8

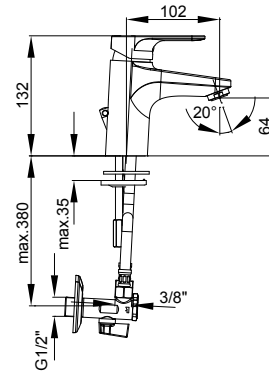

Infinity i10

Art. EAN pkg.
00004 3838963000044 8

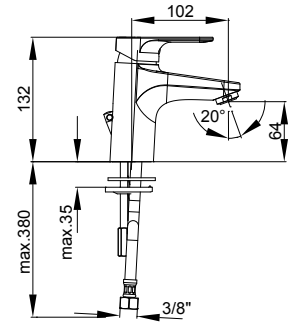

Infinity i50

Art. EAN pkg.
00501 3838963005018 8

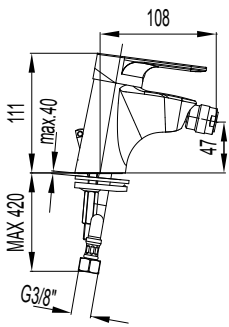

Infinity i50

Art. EAN pkg.
00503 3838963005032 8

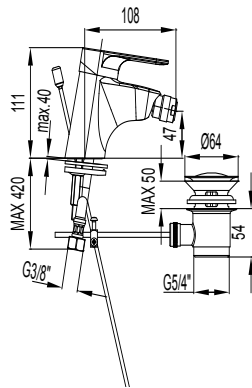

Infinity i12

Art. EAN pkg.
00011 3838963000112 6

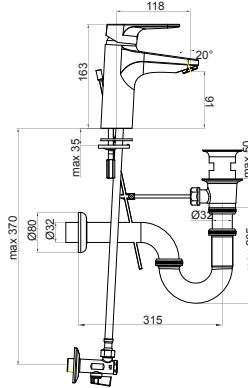

Infinity i12

Art. EAN pkg.
00012 3838963000129 8

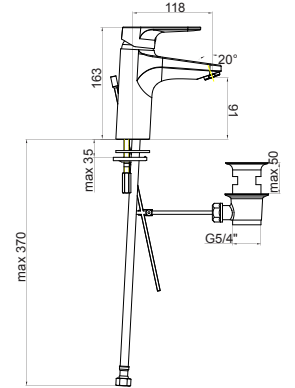

Infinity i12

Art. EAN pkg.
00013 3838963000136 8

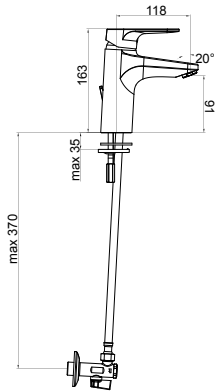

Infinity i12

Art. EAN pkg.
00014 3838963000143 8

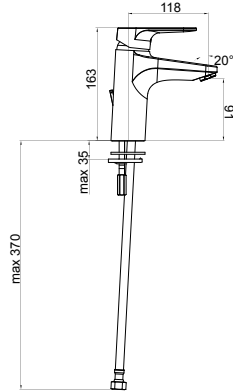

Infinity i12

Art. EAN pkg.
01011 3838963010111 6

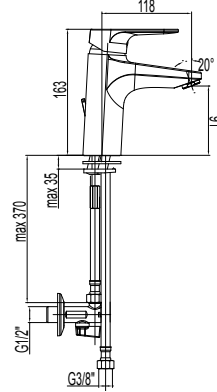

Infinity i20

Art. EAN pkg.
00169 3838963001690 6

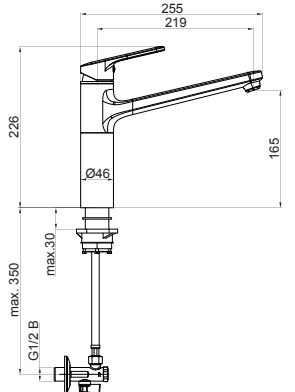

Infinity i20

Art. EAN pkg.
00170 3838963001706 6

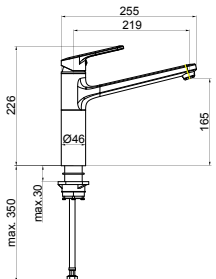

Infinity i20

Art. EAN pkg.
01169 3838963011699 6

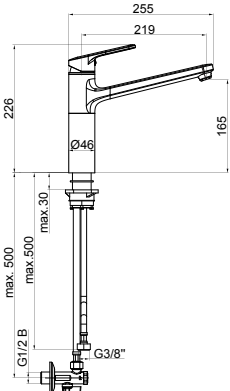

Infinity i21

Art. EAN pkg.
00171 3838963001713 6

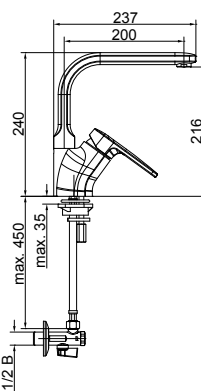

Infinity i21

Art. EAN pkg.
00172 3838963001720 6

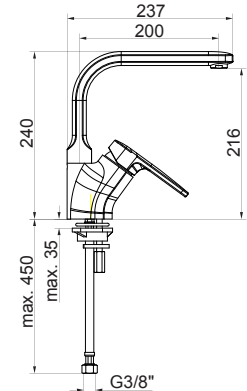

Infinity i21

Art. EAN pkg.
01171 3838963011712 6

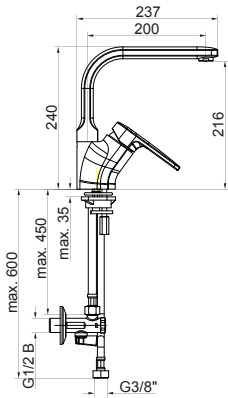

Infinity i22

Art. EAN pkg.
00173 3838963001737 6

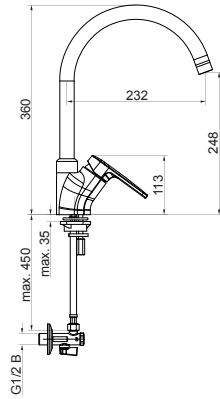

Infinity i22

Art. EAN pkg.
00174 3838963001744 6

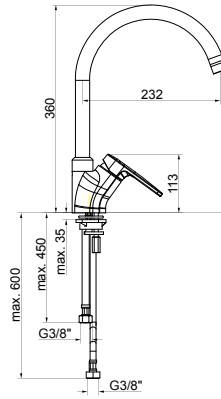

Infinity i22

Art. EAN pkg.
01173 3838963011736 6

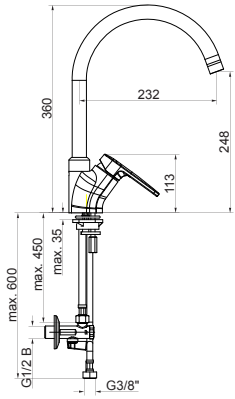

Infinity i23

Art. EAN pkg.
00175 3838963001751 6

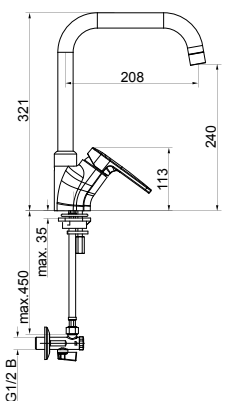

Infinity i23

Art. EAN pkg.
00176 3838963001768 6

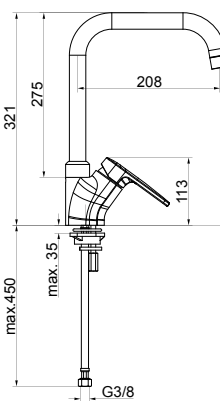

Infinity i23

Art. EAN pkg.
01175 3838963011750 6

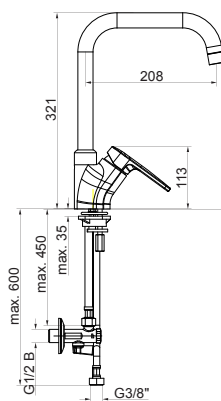

Infinity i30

Art. EAN pkg.
00301 3838963003014 8

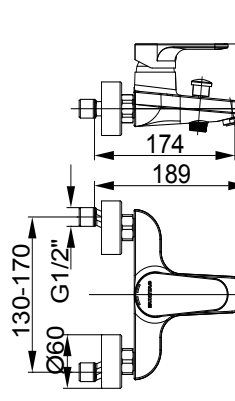

Infinity i30

Art. EAN pkg.
00302 3838963003021 6

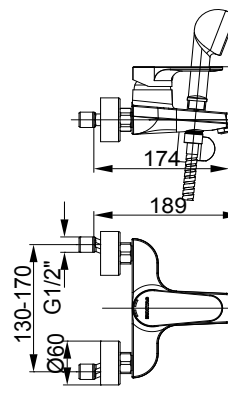

Infinity i30

Art. EAN pkg.
00303 3838963003038 4

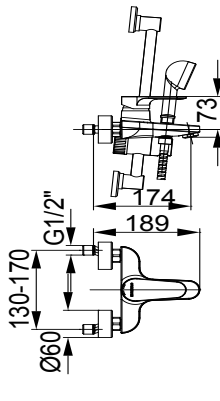

Infinity i40

Art. EAN pkg.
00401 3838963004011 8

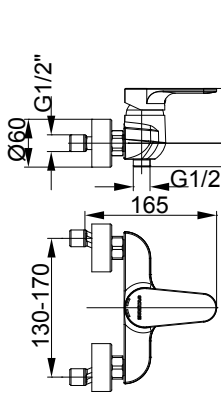

Infinity i40

Art. EAN pkg.
00402 3838963004028 6

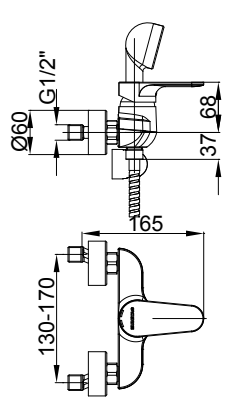

Infinity i40

Art. EAN pkg.
00403 3838963004035 4

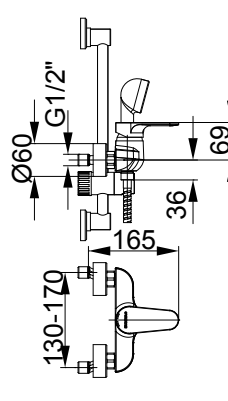

Fresh f10

Art. EAN pkg.
00035 3838963000358 6

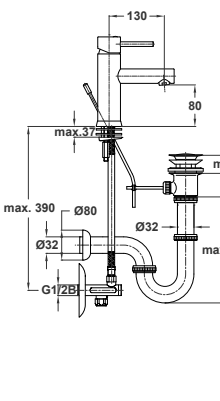

Fresh f10

Art. EAN pkg.
00038 3838963000389 6

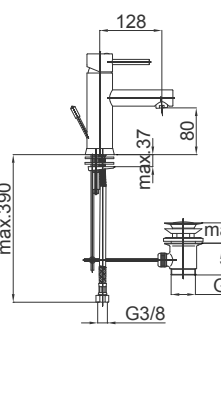

Fresh f10

Art. EAN pkg.
00039 3838963000396 6

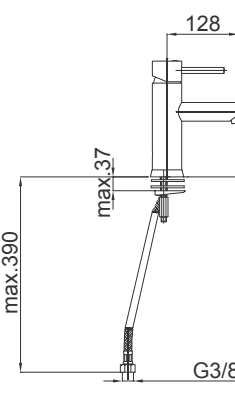

Fresh f10

Art. EAN pkg.
00040 3838963000402 6

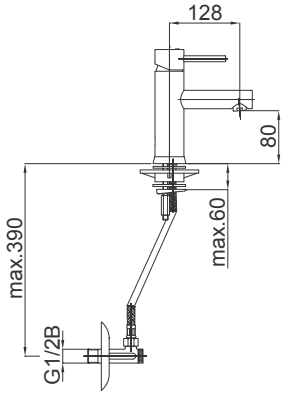

Fresh f10

Art. EAN pkg.
01035 3838963010357 6

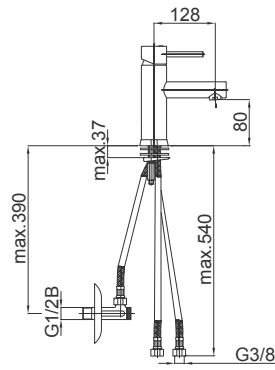

Fresh f11

Art. EAN pkg.
00048 3838963000488 6

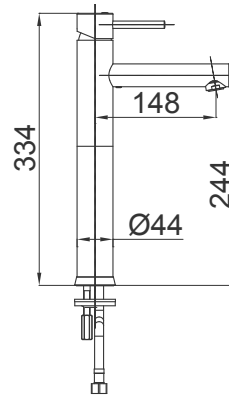

Fresh f11

Art. EAN pkg.
00049 3838963000495 6

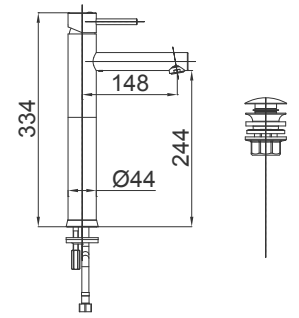

Fresh f12

Art. EAN pkg.
00044 3838963000440 6

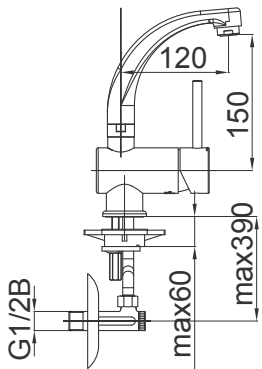

Fresh f12

Art. EAN pkg.
00045 3838963000457 6

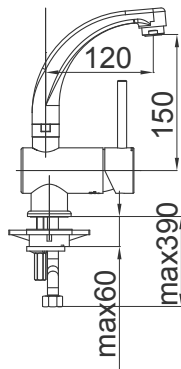

Fresh f50

Art. EAN pkg.
00535 3838963005353 6

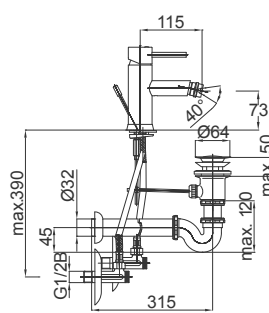

Fresh f50

Art. EAN pkg.
00536 3838963005360 6

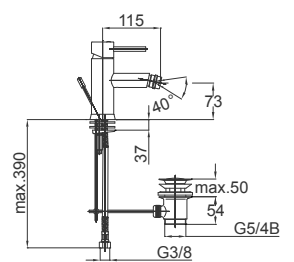

Fresh f50

Art. EAN pkg.
00537 3838963005377 8

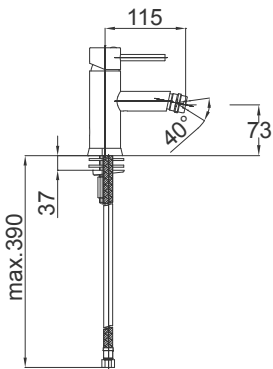

Fresh f20

Art. EAN pkg.
00137 3838963001379 6

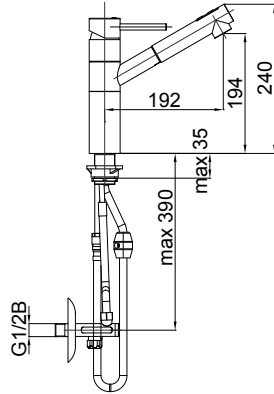

Fresh f20

Art. EAN pkg.
00138 3838963001386 6

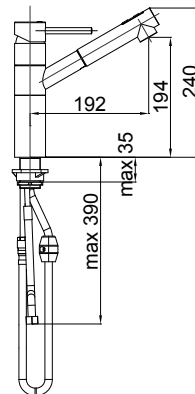

Fresh f21

Art. EAN pkg.
00133 3838963001331 6

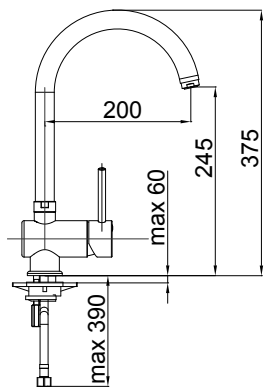

Fresh f21

Art. EAN pkg.
00134 3838963001348 6

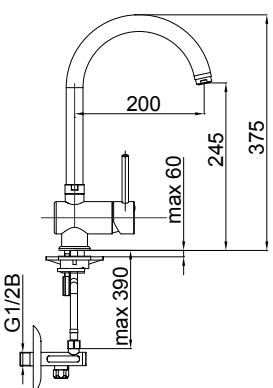

Fresh f21

Art. EAN pkg.
01137 3838963011378 6

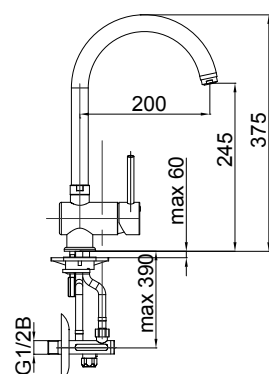

Fresh f22

Art. EAN pkg.
00135 3838963001355 6

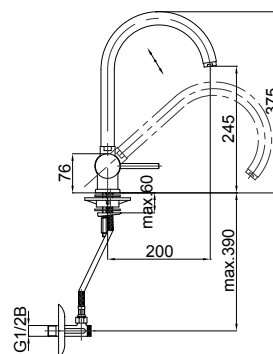

Fresh f22

Art. EAN pkg.
00136 3838963001362 6

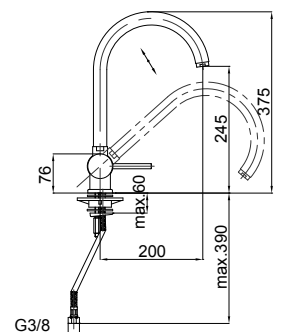

Fresh f22

Art. EAN pkg.
01138 3838963011385 6

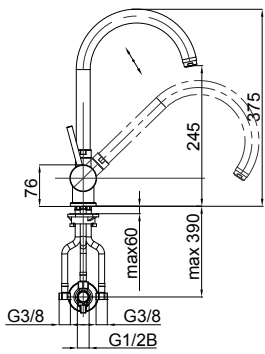

Fresh f23

Art. EAN pkg.
00235 3838963002352 6

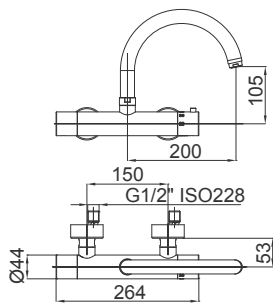

Fresh f30

Art. EAN pkg.
00334 3838963003342 8

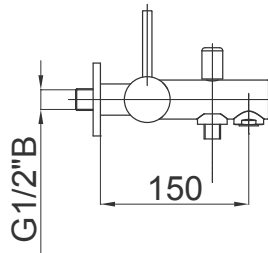

Fresh f30

Art. EAN pkg.
00335 3838963003359 4

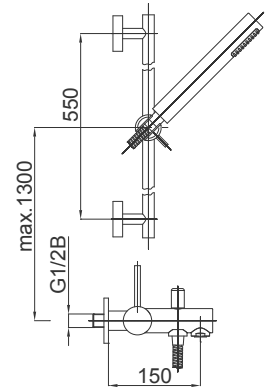

Fresh f30

Art. EAN pkg.
00337 3838963003373 6

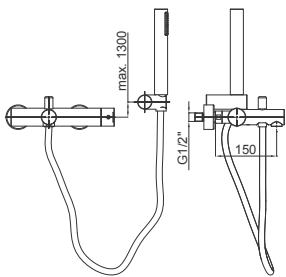

Project m-a1

Art. EAN pkg.
19228 3838963192282 50

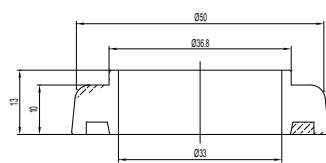

Fresh f31

Art. EAN pkg.
00131 3838963001317 6

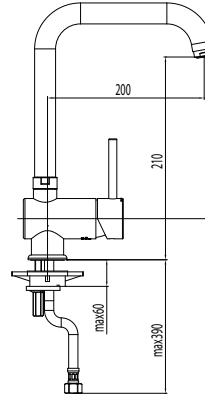

Fresh f31

Art. EAN pkg.
00132 3838963001324 6

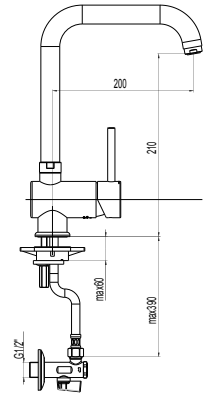

Fresh f31

Art. EAN pkg.
01144 3838963011446 6

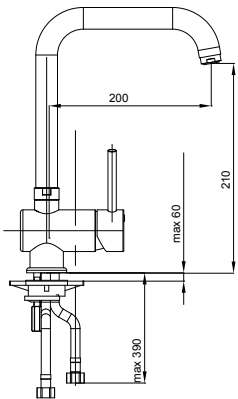

Fresh f31

Art. EAN pkg.
01143 3838963011439 6

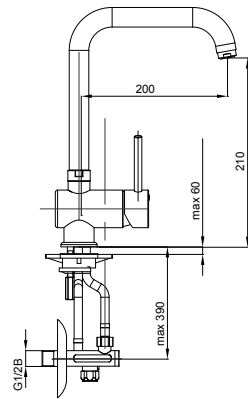

Fresh f32

Art. EAN pkg.
00147 3838963001478 6

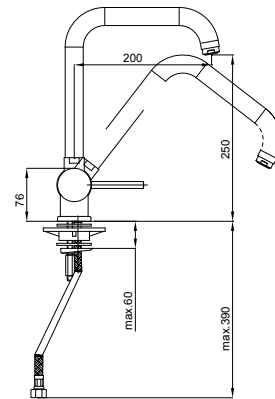

Fresh f32

Art. EAN pkg.
00145 3838963001454 6

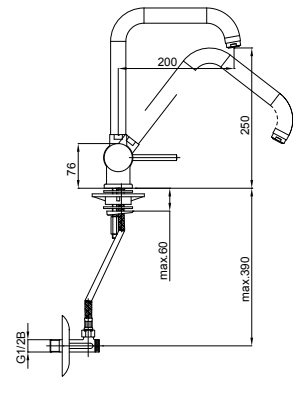

Fresh f32

Art. EAN pkg.
01146 3838963011460 6

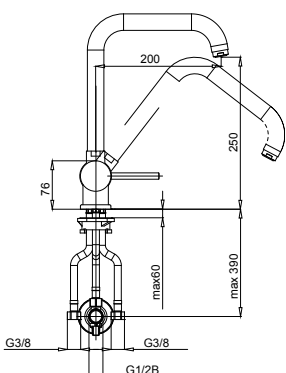

Fresh f40

Art. EAN pkg.
00434 3838963004349 8

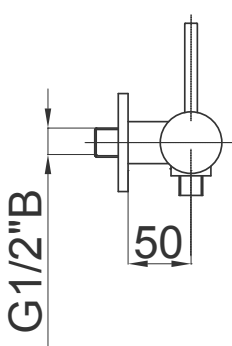

Fresh f40

Art. EAN pkg.
00435 3838963004356 4

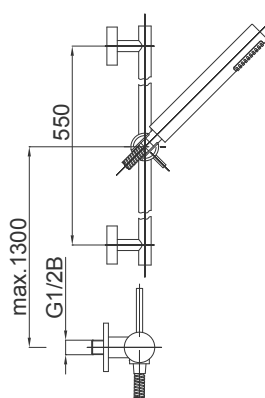

Fresh f40

Art. EAN pkg.
00438 3838963004387 6

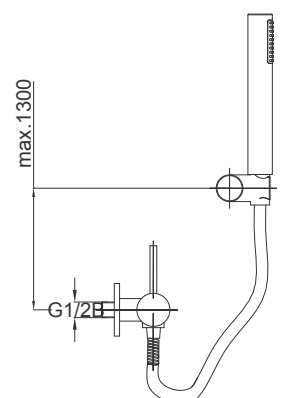

Fresh f41

Art. EAN pkg.
00130 3838963001300 6

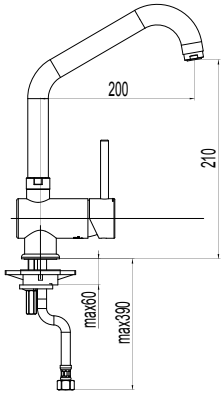

Fresh f41

Art. EAN pkg.
00129 3838963001294 6

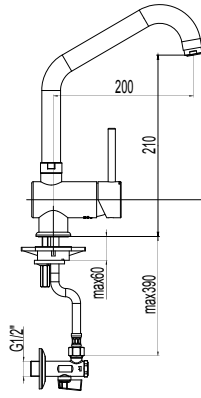

Fresh f41

Art. EAN pkg.
01141 3838963011415 6

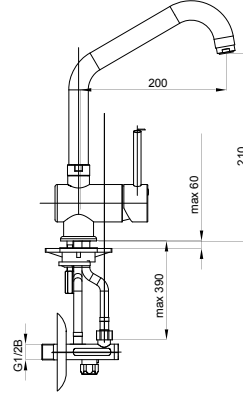

Fresh f41

Art. EAN pkg.
01142 3838963011422 6

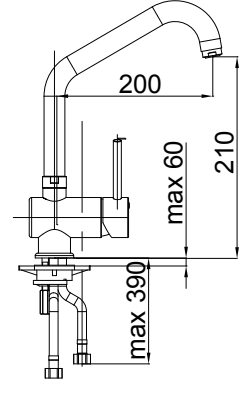

Fresh f42

Art. EAN pkg.
00146 3838963001461 6

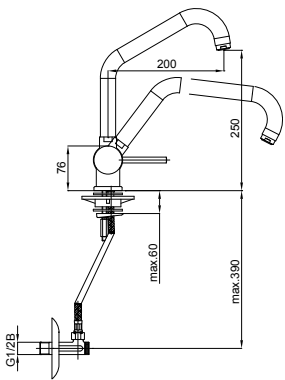

Fresh f42

Art. EAN pkg.
00144 3838963001447 6

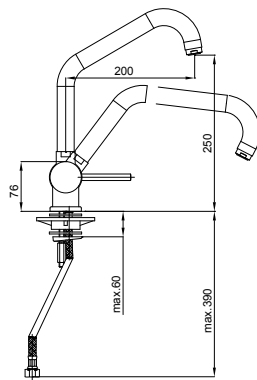

Fresh f42

Art. EAN pkg.
01145 3838963011453 6

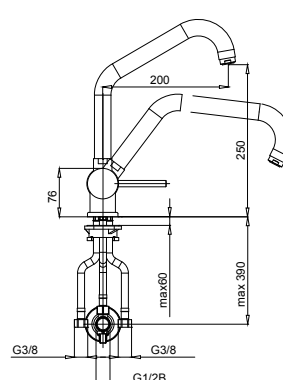

Fresh t30

Art. EAN pkg.
00437 3838963004370 4

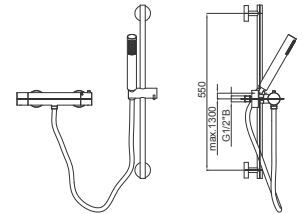

Fresh t30

Art. EAN pkg.
00440 3838963004400 8

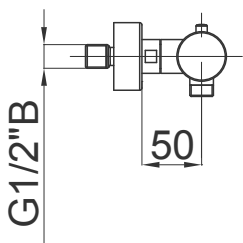

Fresh t40

Art. EAN pkg.
00336 3838963003366 4

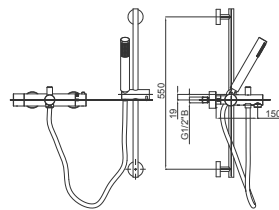

Fresh t40

Art. EAN pkg.
00339 3838963003397 8

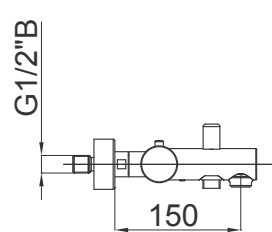

Fresh e10

Art. EAN pkg.
09016 3838963090168 6

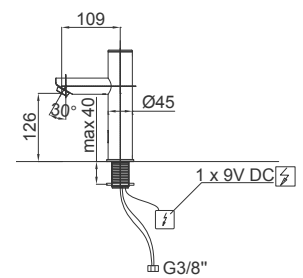

Fresh e10

Art. EAN pkg.
09017 3838963090175 6

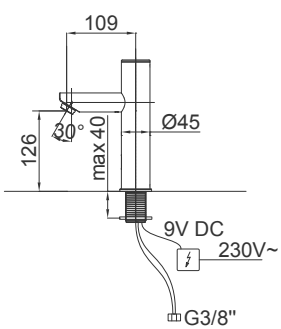

Fresh e11

Art. EAN pkg.
09020 3838963090205 6

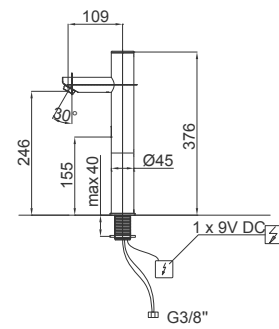

Fresh e11

Art. EAN pkg.
09021 3838963090212 6

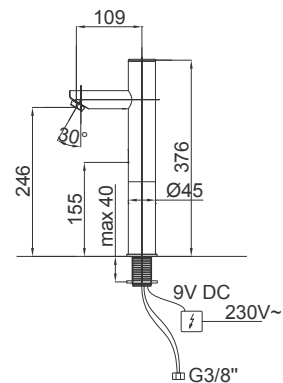

Fresh e12

Art. EAN pkg.
09011 3838963090113 6

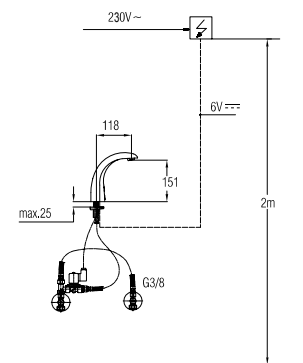

Fresh e12

Art. EAN pkg.
09013 3838963090137 6

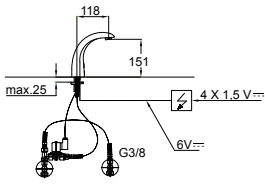

Fresh e15

Art. EAN pkg.
09018 3838963090182 6

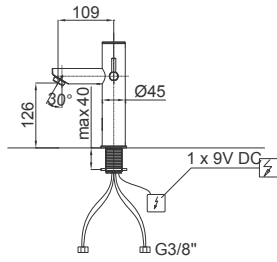

Fresh e15

Art. EAN pkg.
09019 3838963090199 6

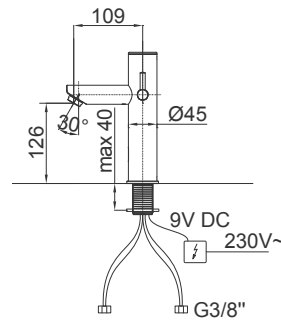

Fresh e16

Art. EAN pkg.
09022 3838963090229 6

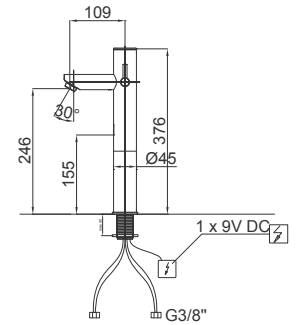

Fresh e16

Art. EAN pkg.
09023 3838963090236 6

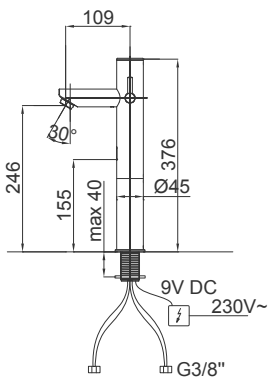

Fresh e40

Art. EAN pkg.
09401 3838963094012 6

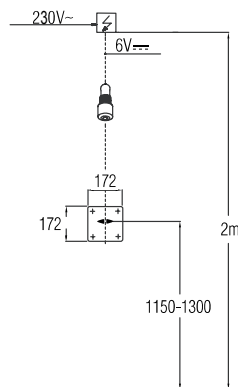

Fresh e40

Art. EAN pkg.
09402 3838963094029 6

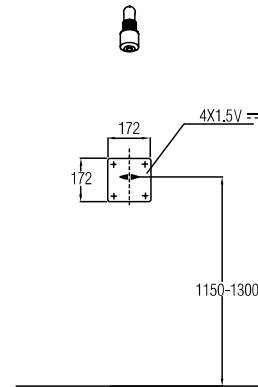

Fresh e50

Art. EAN pkg.
09510 3838963095101 8

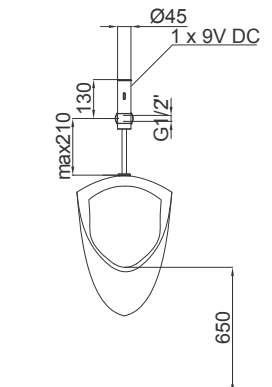

Fresh e60

Art. EAN pkg.
09502 3838963095026 8

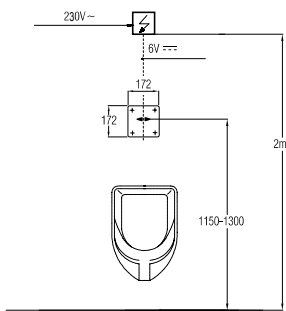

Fresh e60

Art. EAN pkg.
09508 3838963095088 8

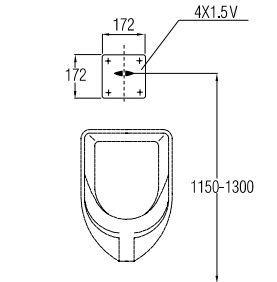

Fresh e61, e62, e63

Art. EAN pkg.
12261 3838963122616 12
12263 3838963122630 12

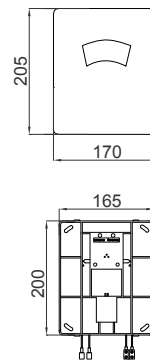

Fresh e70

Art. EAN pkg.
09501 3838963095019 12

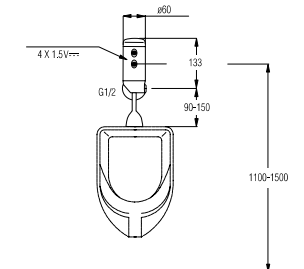

Prestige p10

Art. EAN pkg.
00051 3838963000518 6

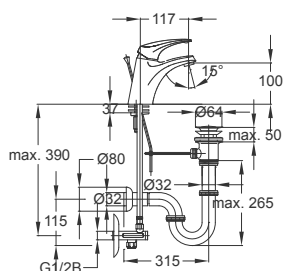

Prestige p10

Art. EAN pkg.
00061 3838963000617 6

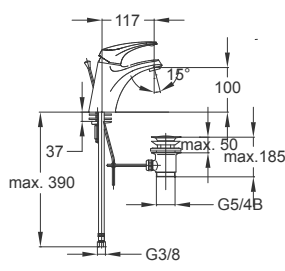

Prestige p10

Art. EAN pkg.
00071 3838963000716 6

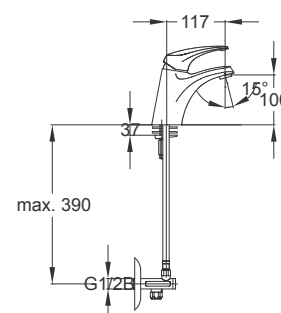

Prestige p11

Art. EAN pkg.
00055 3838963000556 6

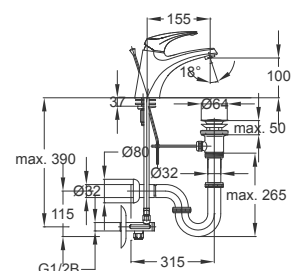

Prestige p11

Art. EAN pkg.
00063 3838963000631 6

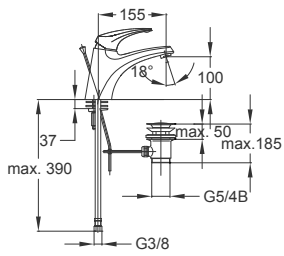

Prestige p11

Art. EAN pkg.
00073 3838963000730 6

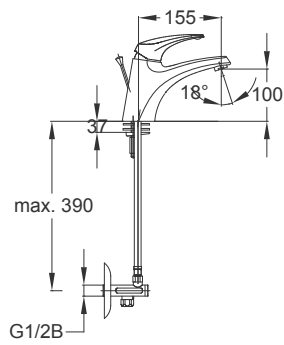

Prestige p50

Art. EAN pkg.
00551 3838963005513 6

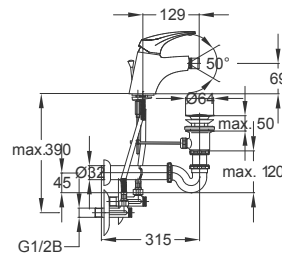

Prestige p50

Art. EAN pkg.
00561 3838963005612 6

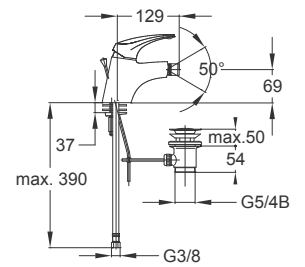

Prestige p50

Art. EAN pkg.
00571 3838963005711 6

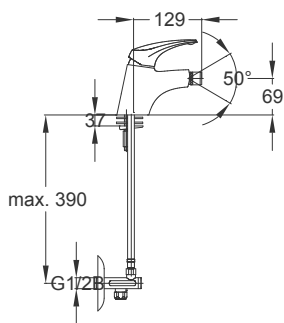

Prestige p40

Art. EAN pkg.
00451 3838963004516 4

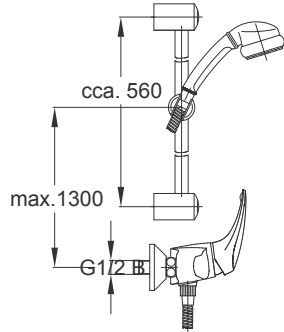

Prestige p40

Art. EAN pkg.
00452 3838963004523 8

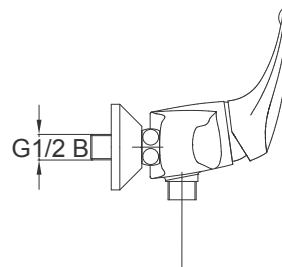

Prestige p40

Art. EAN pkg.
00455 3838963004554 6

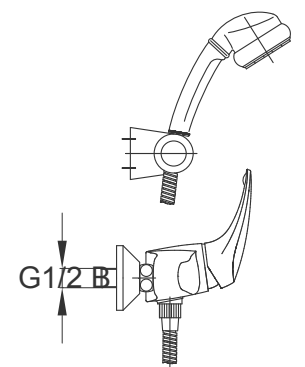

Prestige p30

Art. EAN pkg.
00352 3838963003526 4

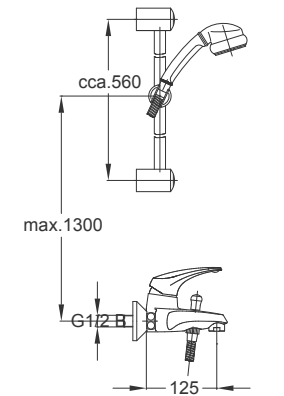

Prestige p30

Art. EAN pkg.
00353 3838963003533 8

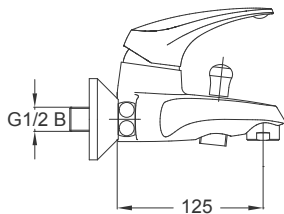

Prestige p30

Art. EAN pkg.
00356 3838963003564 6

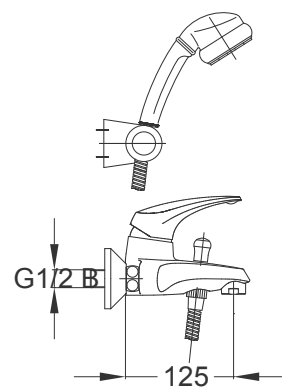

Prestige p20

Art. EAN pkg.
00151 3838963001515 6

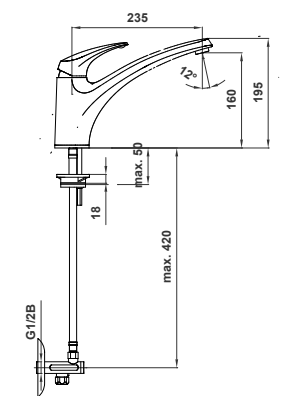

Prestige p20

Art. EAN pkg.
01132 3838963011323 6

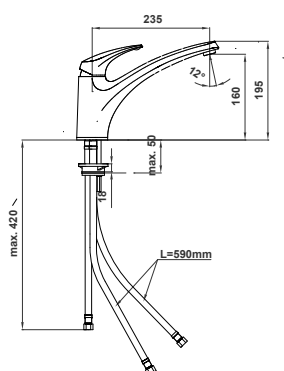

Prestige p21

Art. EAN pkg.
00251 3838963002512 8
00252 3838963002529 8

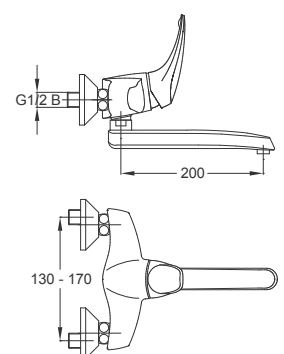

Simpaty s10

Art. EAN pkg.
00081 3838963000815 6

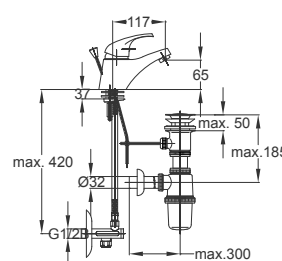

Simpaty s10

Art. EAN pkg.
00082 3838963000822 6

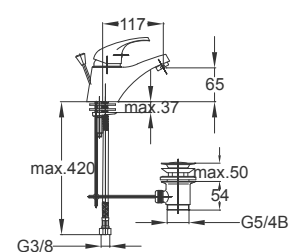

Simpaty s10

Art. EAN pkg.
00083 3838963000839 8

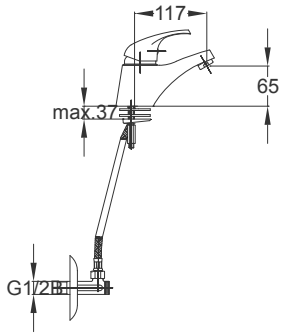

Simpaty s10

Art. EAN pkg.
00084 3838963000846 8

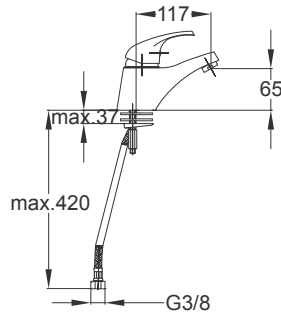

Simpaty s10

Art. EAN pkg.
01081 3838963010814 6

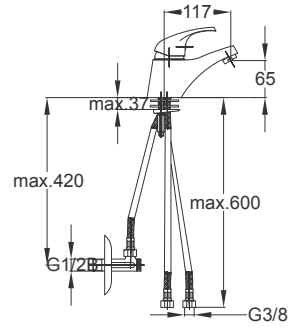

Simpaty s20

Art. EAN pkg.
00182 3838963001829 6

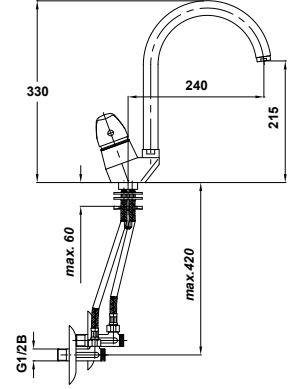

Simpaty s20

Art. EAN pkg.
00186 3838963001867 6

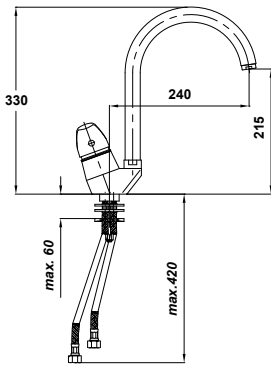

Simpaty s20

Art. EAN pkg.
01182 3838963011828 6

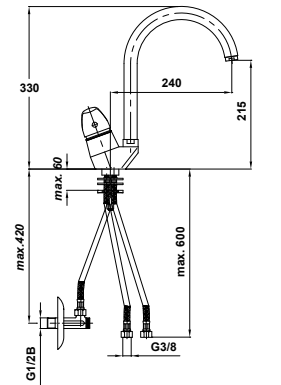

Simpaty s21

Art. EAN pkg.
00181 3838963001812 6

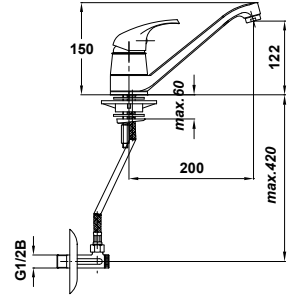

Simpaty s21

Art. EAN pkg.
01181 3838963011811 6

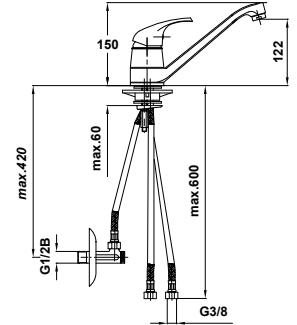

Simpaty s21

Art. EAN pkg.
00183 3838963001836 6

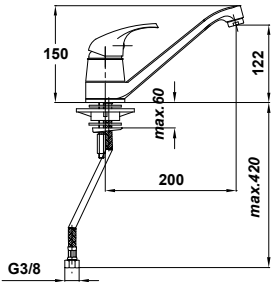

Simpaty s22

Art. EAN pkg.
00281 3838963002819 8

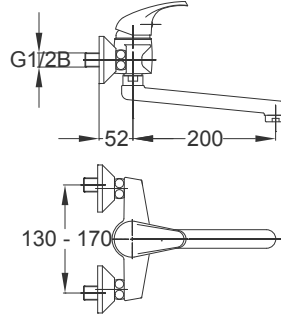

Simpaty s22

Art. EAN pkg.
00282 3838963002826 8

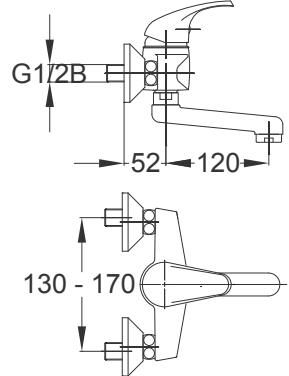

Simpaty s23

Art. EAN pkg.
01281 3838963012818 8

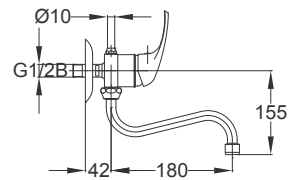

Simpaty s24

Art. EAN pkg.
00237 3838963002376 6

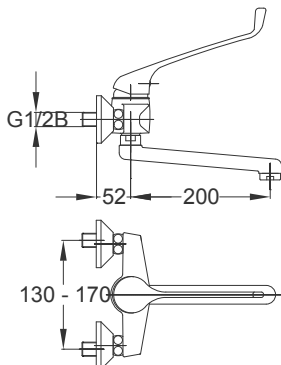

Simpaty s30

Art. EAN pkg.
00189 3838963001898 6

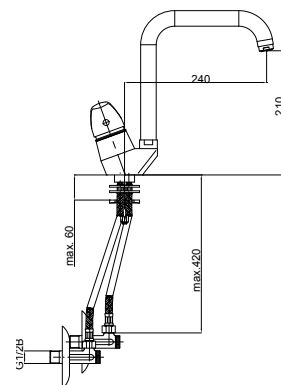

Simpaty s30

Art. EAN pkg.
00188 3838963001881 6

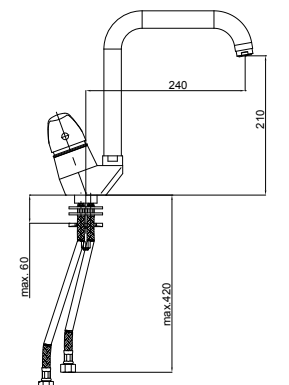

Simpaty s30

Art. EAN pkg.
01189 3838963011897 6

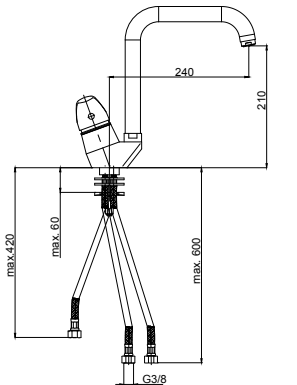

Simpaty s30

Art. EAN pkg.
01188 3838963011880 6

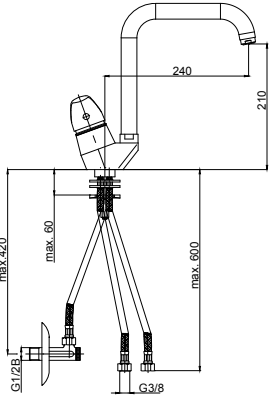

Simpaty s31

Art. EAN pkg.
00388 3838963003885 8

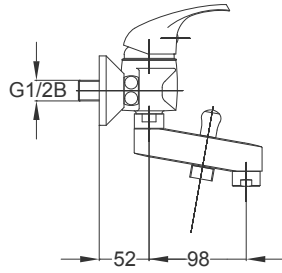

Simpaty s31

Art. EAN pkg.
00389 3838963003892 6

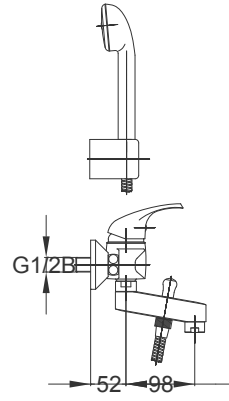

Simpaty s39

Art. EAN pkg.
00480 3838963004806 8

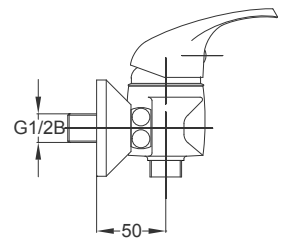

Simpaty s40

Art. EAN pkg.
00190 3838963001904 6

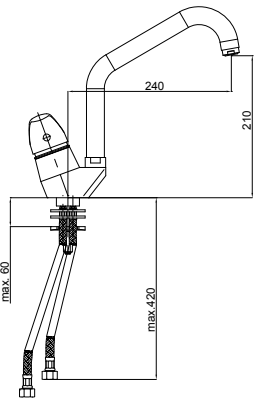

Simpaty s40

Art. EAN pkg.
01187 3838963011873 6

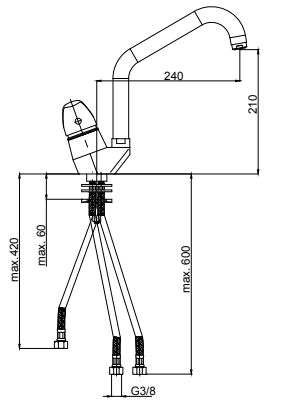

Simpaty s40

Art. EAN pkg.
01186 3838963011866 6

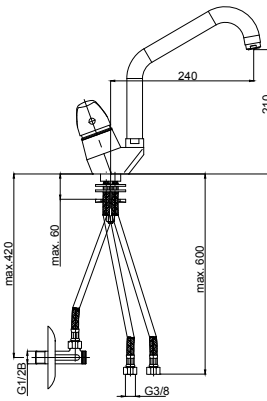

Simpaty s40

Art. EAN pkg.
00193 3838963001935 6

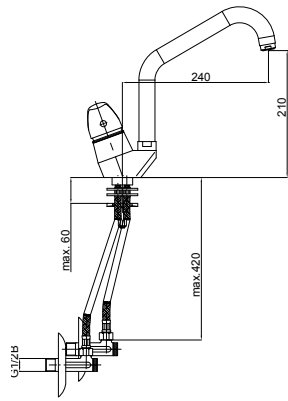

Simpaty s41

Art. EAN pkg.
00383 3838963003830 6

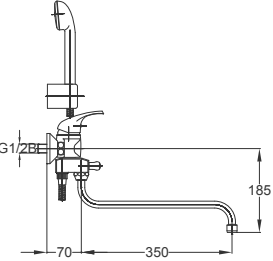

Simpaty s42

Art. EAN pkg.
01381 3838963013815 9

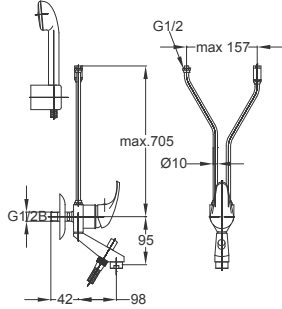

Simpaty s50

Art. EAN pkg.
00581 3838963005810 6

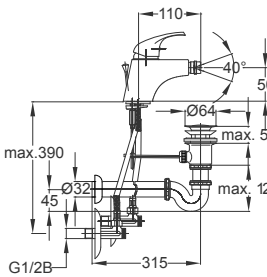

Simpaty s50

Art. EAN pkg.
00582 3838963005827 6

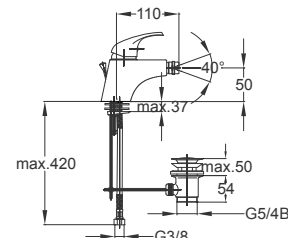

Simpaty s50

Art. EAN pkg.
00584 3838963005841 8

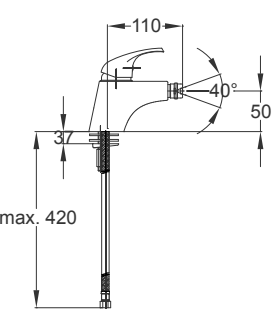

Simpaty s51

Art. EAN pkg.
00037 3838963000372 6

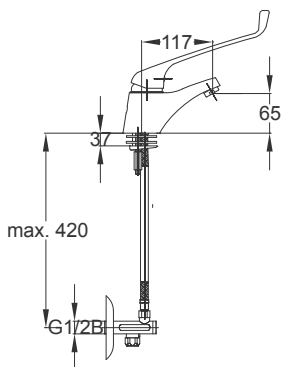

Simpaty s32

Art. EAN pkg.
00380 3838963003809 8
00381 3838963003816 6

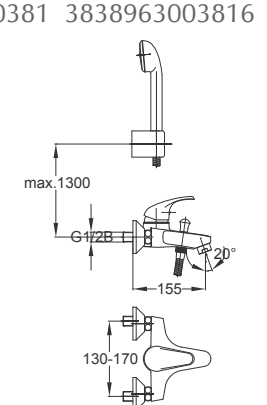

Simpaty s32

Art. EAN pkg.
00384 3838963003847 4

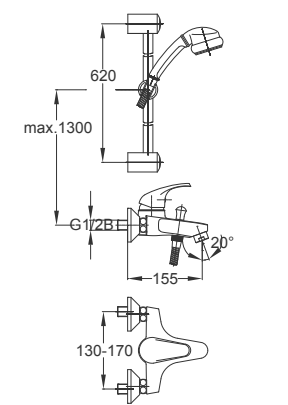

Project m10

Art. EAN pkg.
00023 3838963000235 6

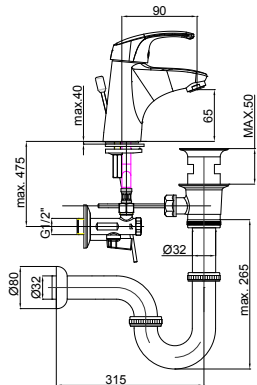

Project m10

Art. EAN pkg.
00024 3838963000242 8

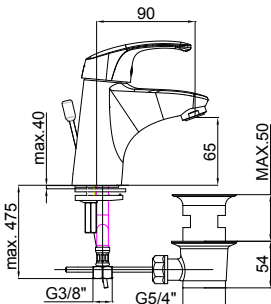

Project m10

Art. EAN pkg.
00025 3838963000259 8

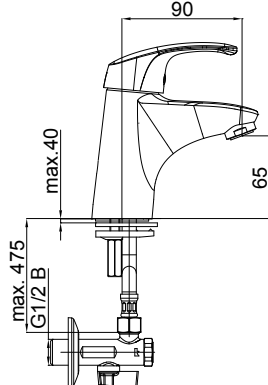

Project m20

Art. EAN pkg.
00184 3838963001843 6

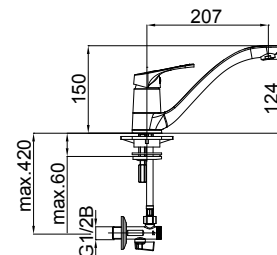

Project m20

Art. EAN pkg.
00185 3838963001850 6

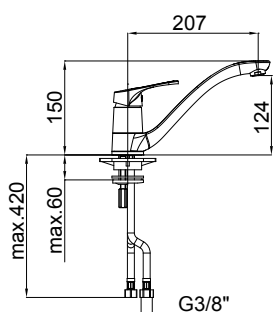

Project m20

Art. EAN pkg.
01185 3838963011859 6

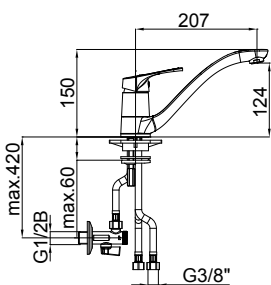

Project m30

Art. EAN pkg.
00325 3838963003250 6

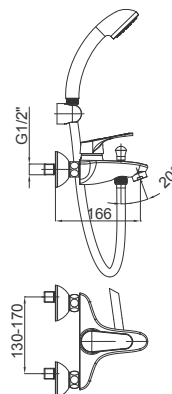

Project m30

Art. EAN pkg.
00326 3838963003267 8

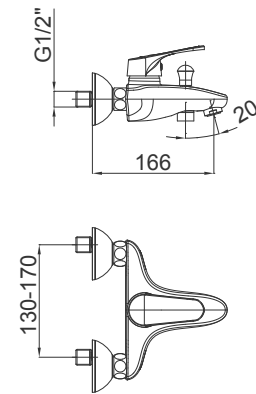

Project m40

Art. EAN pkg.
00425 3838963004257 6

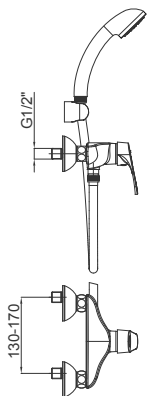

Project m40

Art. EAN pkg.
00427 3838963004271 8

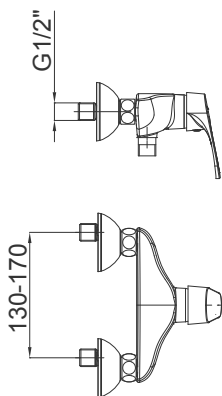

Project m50

Art. EAN pkg.
00515 3838963005155 6

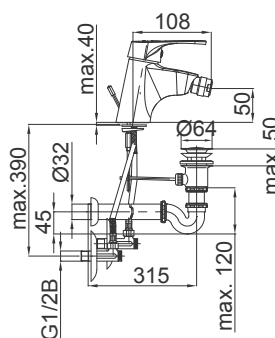

Project m50

Art. EAN pkg.
00516 3838963005162 8

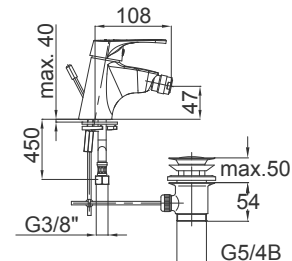

Project m50

Art. EAN pkg.
00518 3838963005186 8

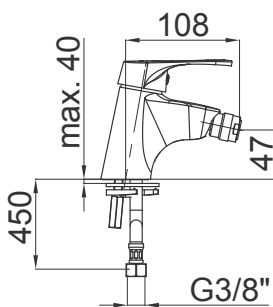

Stil z10, z11

Art. EAN pkg.
07061 3838963070610 8
07063 3838963070634 8

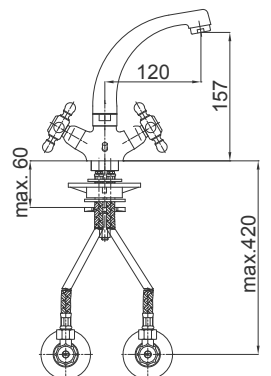

Stil z10, z11

Art. EAN pkg.
07066 3838963070665 8
07068 3838963070689 8

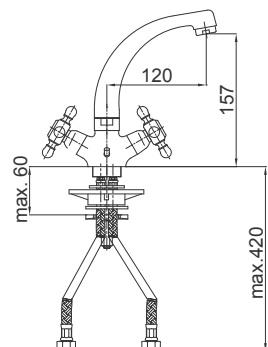

Stil z10, z11

Art. EAN pkg.
07072 3838963070726 8
07073 3838963070733 8

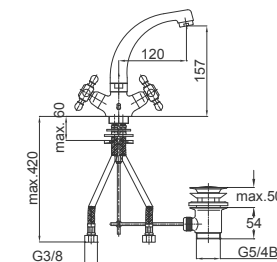

Stil z12, z13

Art.	EAN	pkg.
07062	3838963070627	8
07064	3838963070641	8

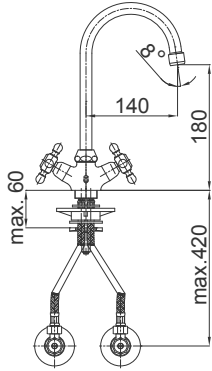

Stil z12, z13

Art.	EAN	pkg.
07067	3838963070672	8
07078	3838963070788	8

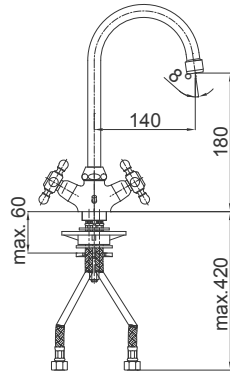

Stil z12, z13

Art.	EAN	pkg.
07077	3838963070771	8
07079	3838963070795	8

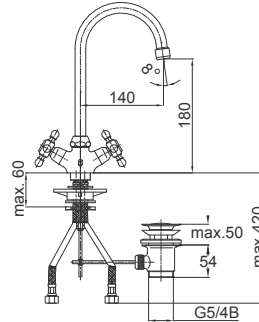

Stil z20, z40

Art.	EAN	pkg.
07162	3838963071624	8
07169	3838963071693	8

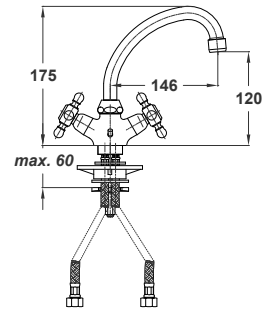

Stil z20, z40

Art.	EAN	pkg.
08149	3838963081494	6
08150	3838963081500	6

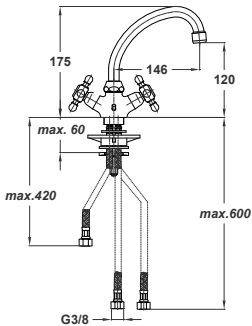

Stil z20, z40

Art.	EAN	pkg.
07158	3838963071587	8
07156	3838963071563	8

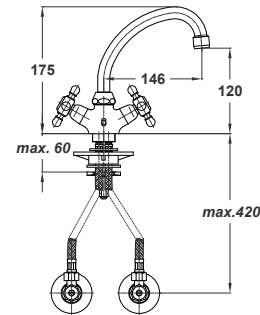

Stil z22, z42

Art.	EAN	pkg.
08160	3838963081609	6
08161	3838963081616	6

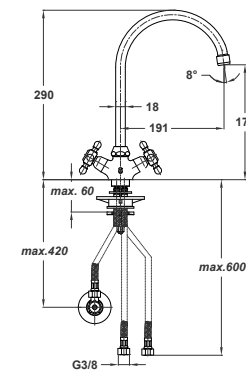

Stil z22, z42

Art.	EAN	pkg.
07157	3838963071570	6
07159	3838963071594	6

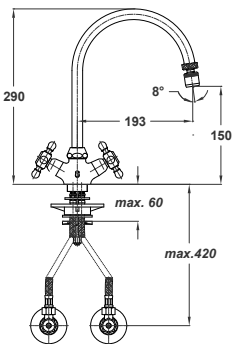

Stil z22, z42

Art.	EAN	pkg.
07163	3838963071631	6
07165	3838963071655	6

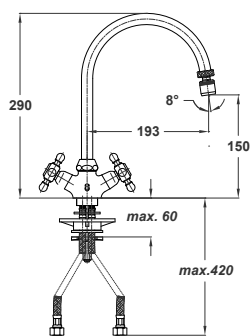

Stil z25, z45

Art.	EAN	pkg.
07263	3838963072638	12
07260	3838963072607	12

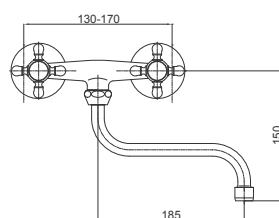

Stil z26, z46

Art.	EAN	pkg.
07261	3838963072614	12
07264	3838963072645	12

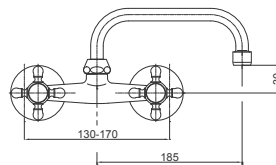

Stil z27, z47

Art.	EAN	pkg.
07262	3838963072621	12
07265	3838963072652	12

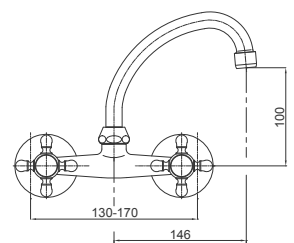

Stil z30, z31

Art.	EAN	pkg.
07357	3838963073574	6
07358	3838963073581	6

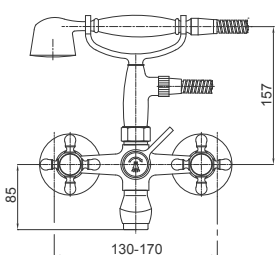

Stil z40, z41

Art.	EAN	pkg.
07462	3838963074625	6
07464	3838963074649	6

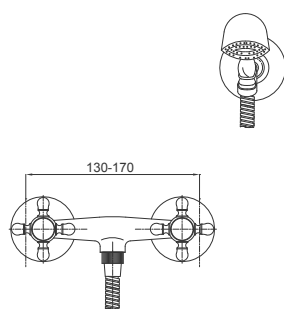

Stil z40, z41

Art.	EAN	pkg.
07465	3838963074656	12
07466	3838963074663	12

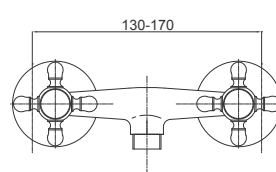

Stil z50, z51

Art.	EAN	pkg.
07554	3838963075547	6
07555	3838963075554	6

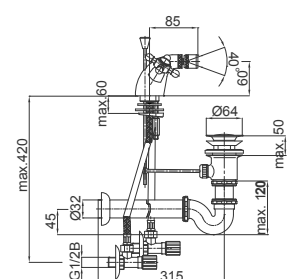

Stil z50, z51

Art.	EAN	pkg.
07558	3838963075585	8
07559	3838963075592	8

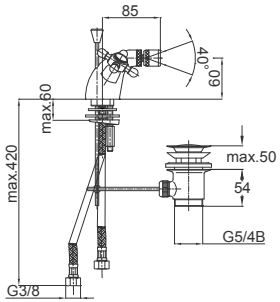

Stil z200, z400

Art.	EAN	pkg.
08255	3838963082552	12
08266	3838963082668	1

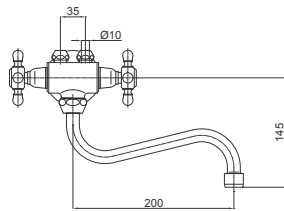

Classic c01

Art.	EAN	pkg.
10052	3838963100522	50

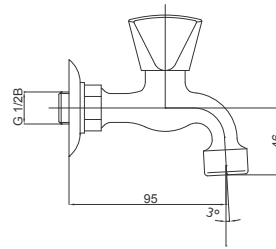

Classic c02

Art.	EAN	pkg.
10151	3838963101512	50

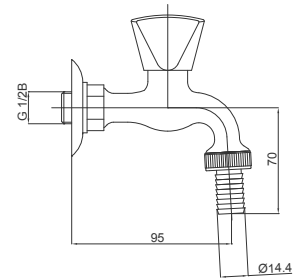

Classic c03

Art.	EAN	pkg.
10152	3838963101529	50

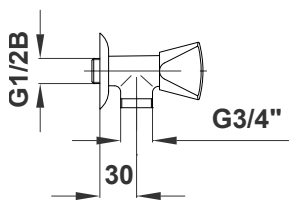

Classic c04

Art.	EAN	pkg.
10251	3838963102519	24

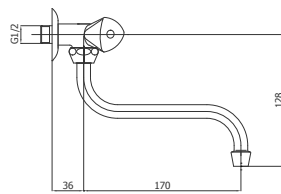

Classic c05

Art.	EAN	pkg.
10351	3838963103516	24

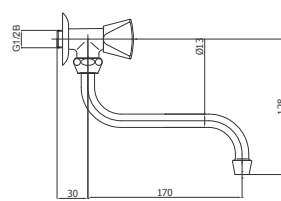

Classic c06

Art.	EAN	pkg.
10352	3838963103523	12

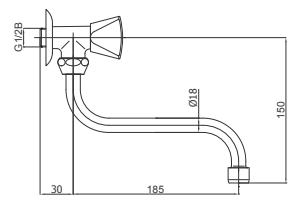

Classic c07

Art.	EAN	pkg.
10354	3838963103547	12

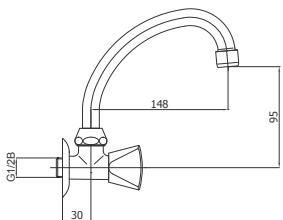

Classic c08

Art.	EAN	pkg.
10355	3838963103554	24

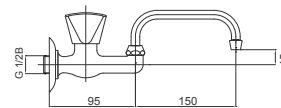

Classic c09

Art.	EAN	pkg.
10356	3838963103561	50

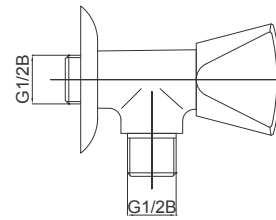

Classic c10

Art.	EAN	pkg.
05055	3838963050551	8

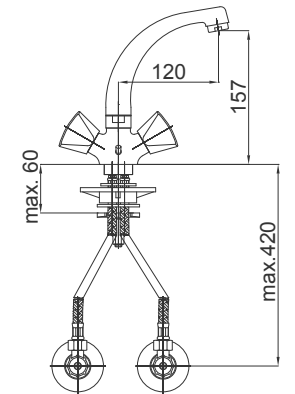

Classic c10

Art.	EAN	pkg.
05056	3838963050568	8

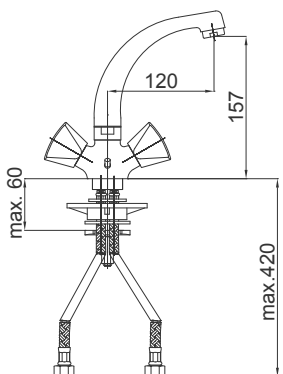

Classic c11

Art.	EAN	pkg.
10651	3838963106517	24

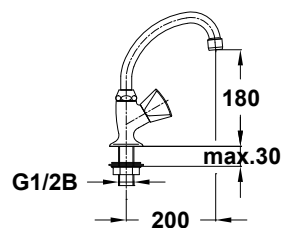

Classic c12

Art.	EAN	pkg.
10652	3838963106524	8

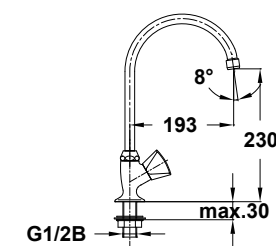

Classic c15

Art.	EAN	pkg.
10551	3838963105510	24

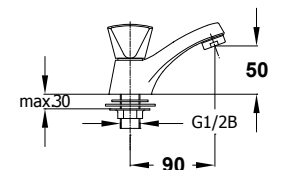

Classic c20

Art. EAN pkg.
05153 3838963051534 8

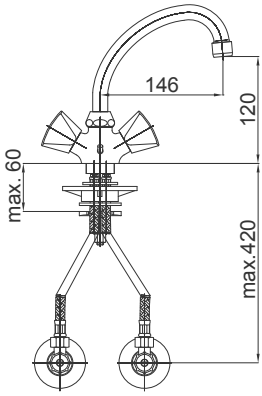

Classic c20

Art. EAN pkg.
05154 3838963051541 8

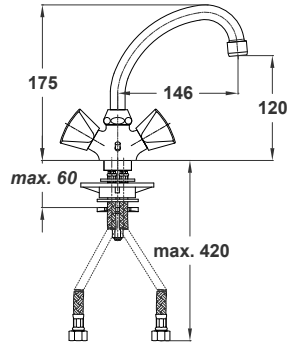

Classic c20

Art. EAN pkg.
06156 3838963061564 8

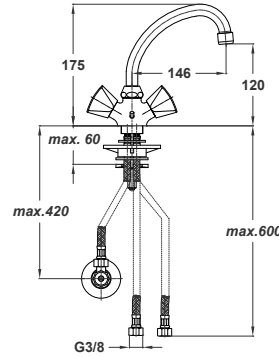

Classic c21

Art. EAN pkg.
05251 3838963052517 12

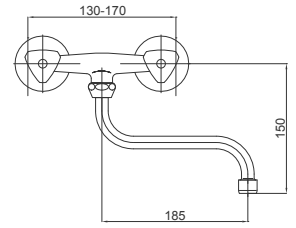

Classic c22

Art. EAN pkg.
05252 3838963052524 12

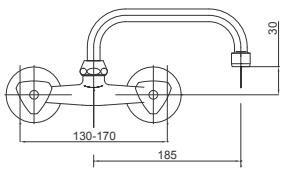

Classic c23

Art. EAN pkg.
05253 3838963052531 12

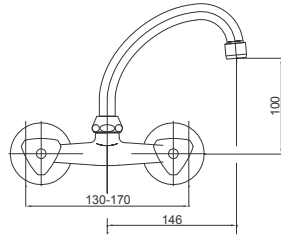

Classic c24

Art. EAN pkg.
06251 3838963062516 24

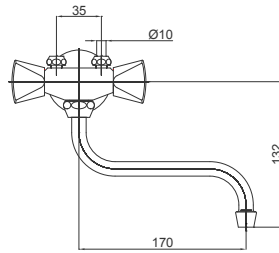

Classic c30

Art. EAN pkg.
05351 3838963053514 6

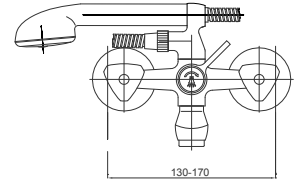

Classic c31

Art. EAN pkg.
05355 3838963053552 6

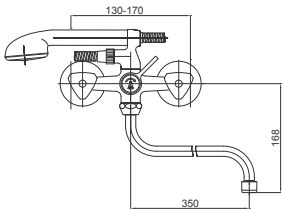

Classic c40

Art. EAN pkg.
05452 3838963054528 12

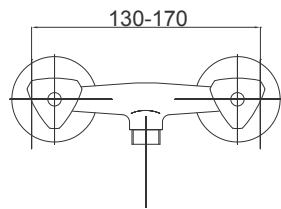

Classic c40

Art. EAN pkg.
05451 3838963054511 6

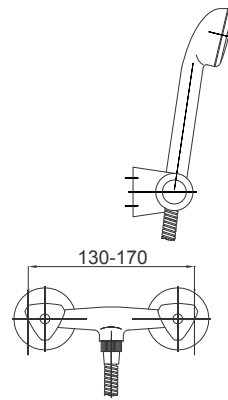

Classic c41

Art. EAN pkg.
05454 3838963054542 12

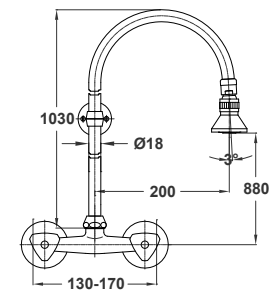

Classic c42

Art. EAN pkg.
05455 3838963054559 8

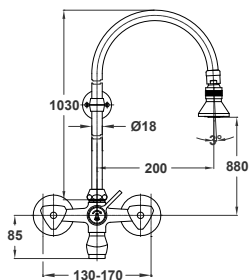

Classic c43

Art. EAN pkg.
10451 3838963104513 12

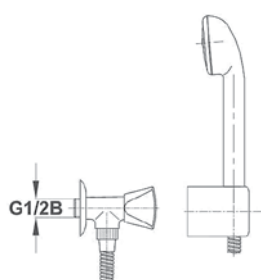

Classic c44

Art. EAN pkg.
10452 3838963104520 24

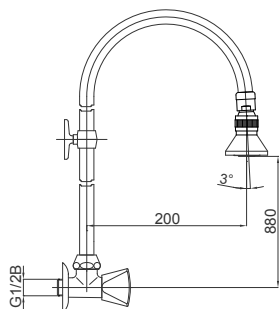

Classic c50

Art. EAN pkg.
05553 3838963055532 6

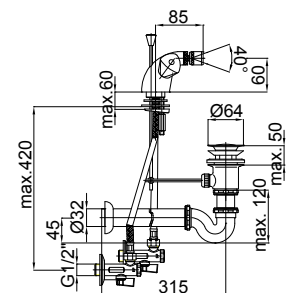

Classic c50

Art. EAN pkg.
05557 3838963055570 8

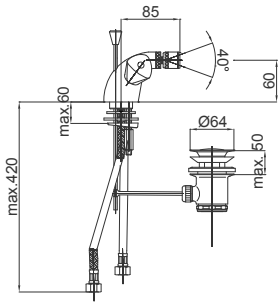

Classic c50

Art. EAN pkg.
05554 3838963055549 8

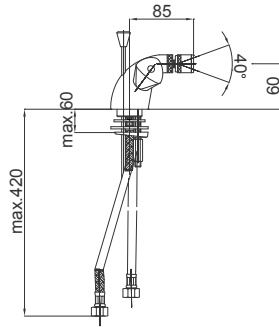

Harmony h10

Art. EAN pkg.
00091 3838963000914 6

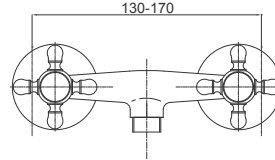

Harmony h10

Art. EAN pkg.
00092 3838963000921 6

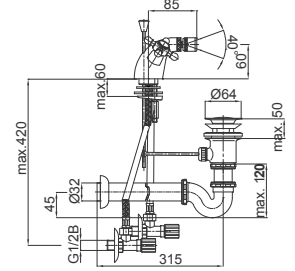

Harmony h10

Art. EAN pkg.
00093 3838963000938 8

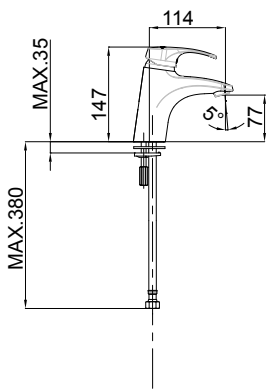

Harmony h10

Art. EAN pkg.
00094 3838963000945 8

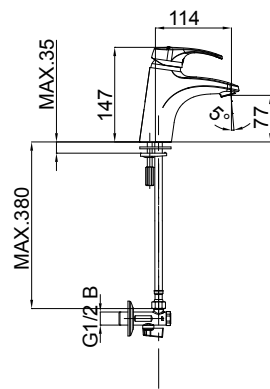

Harmony h10

Art. EAN pkg.
01095 3838963010951 6

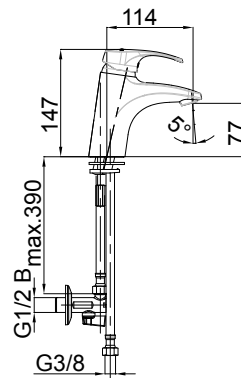

Harmony h21

Art. EAN pkg.
00291 3838963000945 8
00292 3838963001928 6

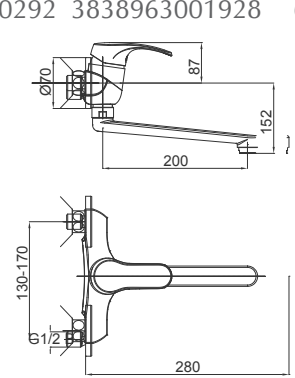

Harmony h30

Art. EAN pkg.
00393 3838963003939 6

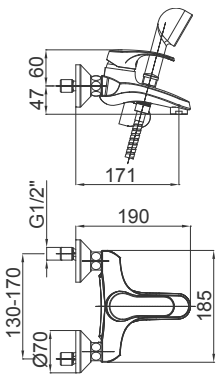

Harmony h30

Art. EAN pkg.
00394 3838963003946 4

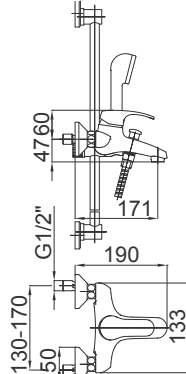

Harmony h30

Art. EAN pkg.
00395 3838963003953 8

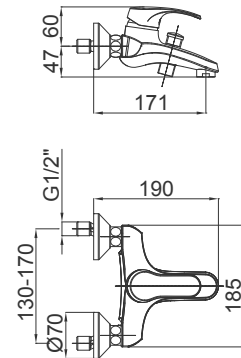

Harmony h40

Art. EAN pkg.
00491 3838963004912 6

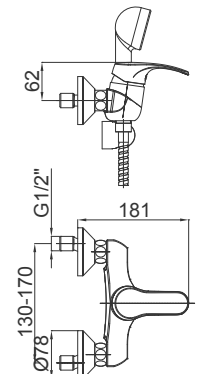

Harmony h40

Art. EAN pkg.
00492 3838963004929 4

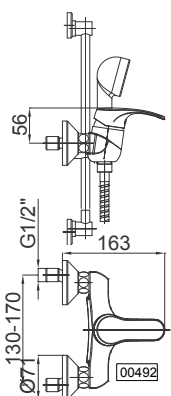

Harmony h40

Art. EAN pkg.
00493 3838963004936 8

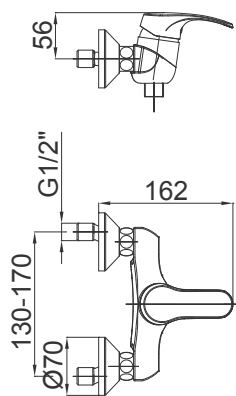

Harmony h50

Art. EAN pkg.
00591 3838963005919 6

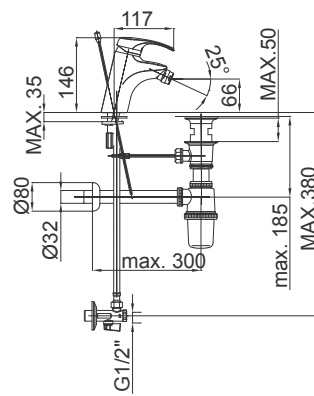

Harmony h50

Art. EAN pkg.
00592 3838963005926 6

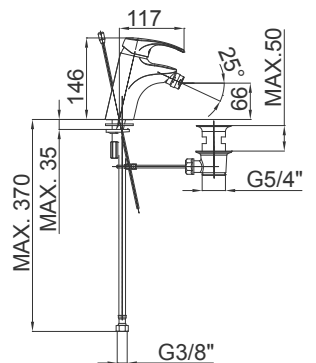

Harmony h50

Art. EAN pkg.
00594 3838963005940 8

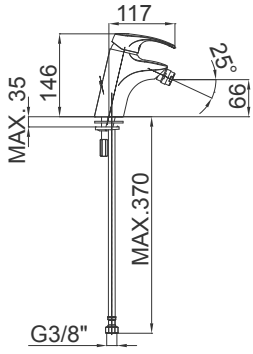

Pure a01

Art. EAN pkg.
12050 3838963120506 12

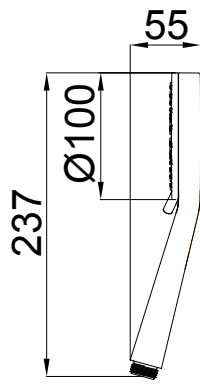

Thin a02

Art. EAN pkg.
12051 3838963120513 12

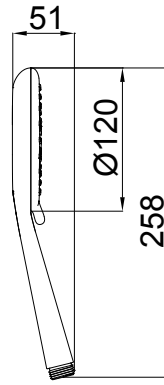

Smart a03

Art. EAN pkg.
12052 3838963120520 12

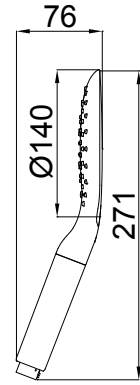

Infinity a04

Art. EAN pkg.
12043 3838963120438 1

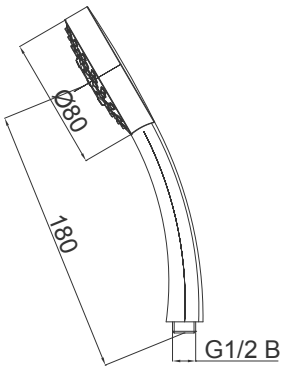

Infinity a05

Art. EAN pkg.
12460 3838963124603 9

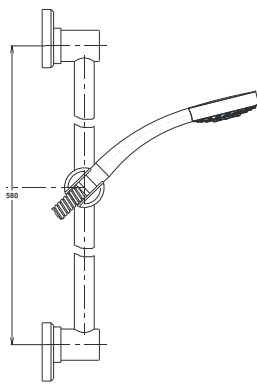

Pure S a06

Art. EAN pkg.
12461 3838963124610 9

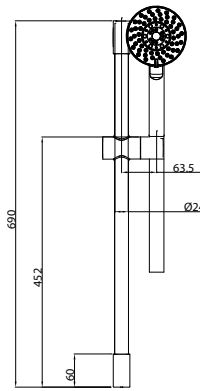

Smart a07

Art. EAN pkg.
12462 3838963124627 9

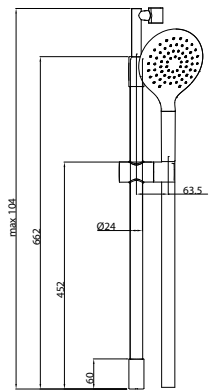

Prha a08

Art. EAN pkg.
12103 3838963121039 12

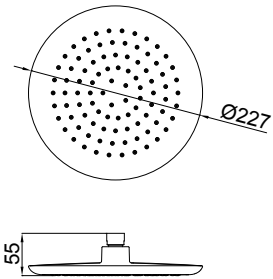

Prha a09

Art. EAN pkg.
12106 3838963121060 6

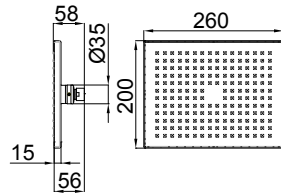

Prha a10

Art. EAN pkg.
12104 3838963121046 12

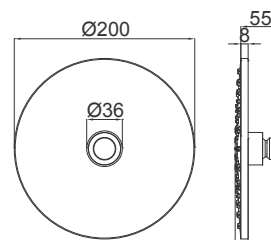

Pure waterfall a11

Art. EAN pkg.
12551 3838963125518 2

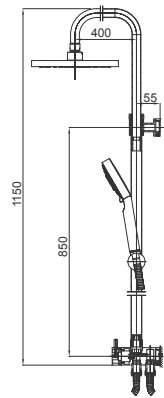

Smart a12

Art. EAN pkg.
12552 3838963125228 1

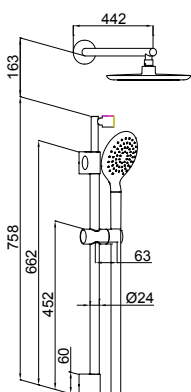

Fresh a13

Art. EAN pkg.
12452 3838963124528 9

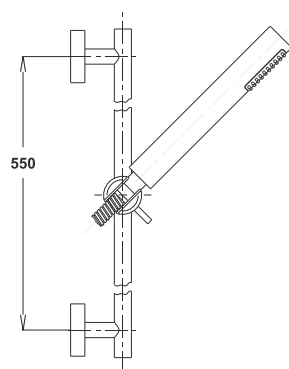

Simpaty a20

Art. EAN pkg.
12358 3838963123583 8

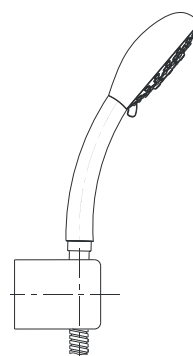

Project a23

Art. EAN pkg.
12354 3838963123545 8

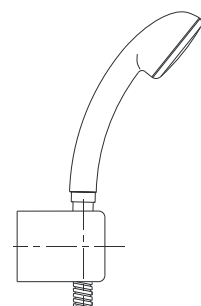

Smart a03w

Art. EAN pkg.
12053 3838963120537 12

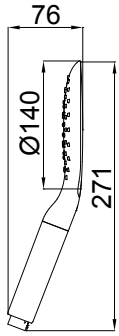

Stil 12455

Art. EAN pkg.
12455 3838963124559 9

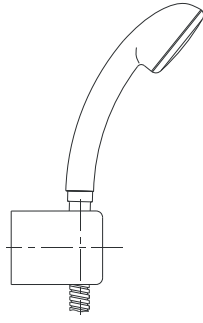

Stil 12355

Art. EAN pkg.
12355 3838963123552 12

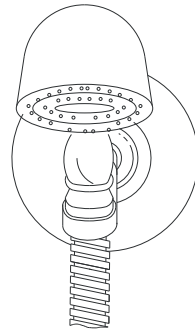

P. A.

Art. EAN pkg.
00367 3838963003670 12

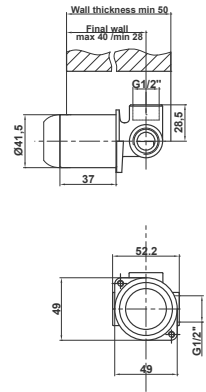

P. A.

Art. EAN pkg.
00368 3838963003687 8

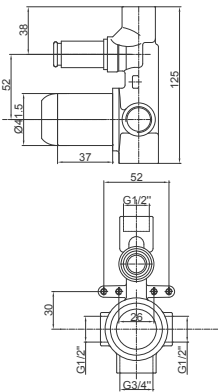

P. A. Fresh

Art. EAN pkg.
12259 3838963122593 12

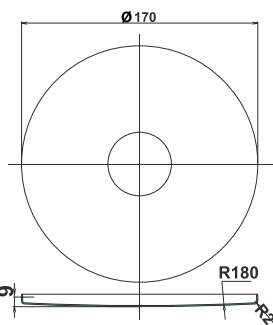

P. A. Fresh

Art. EAN pkg.
12260 3838963122609 12

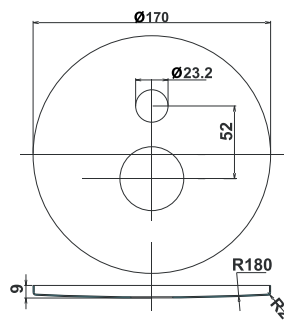

P. A. Project

Art. EAN pkg.
12251 3838963122517 12

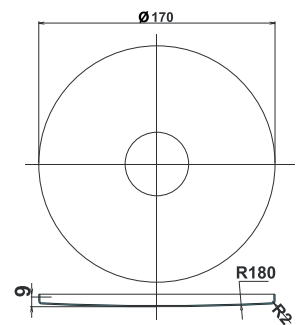

P. A. Project

Art. EAN pkg.
12252 3838963122524 12

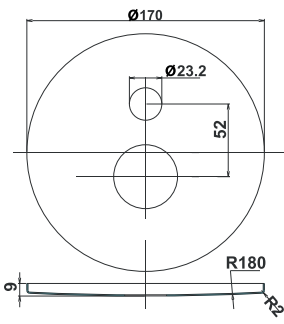

P. A. Infinity

Art. EAN pkg.
12249 3838963122494 12

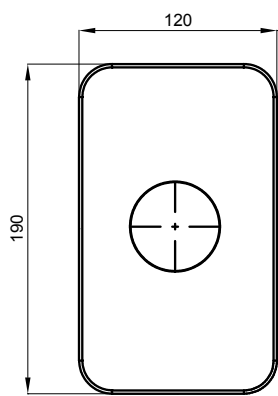

P. A. Infinity

Art. EAN pkg.
12250 3838963122500 12

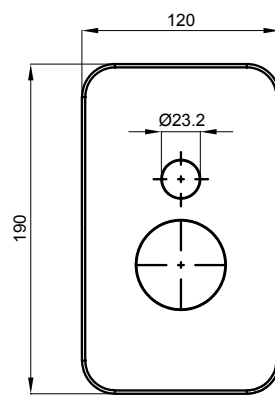

P. A. Simpaty

Art. EAN pkg.
12253 3838963122531 12

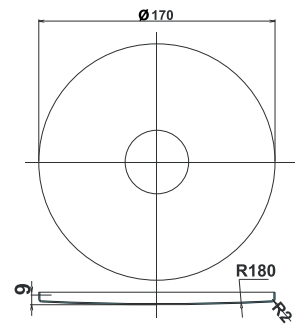

P. A. Simpaty

Art. EAN pkg.
12254 3838963122548 12

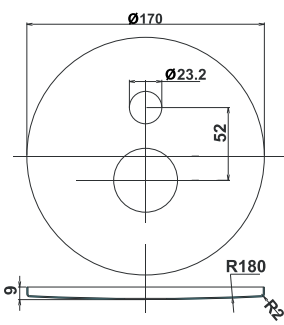

P. A. Harmony

Art. EAN pkg.
12255 3838963122555 12

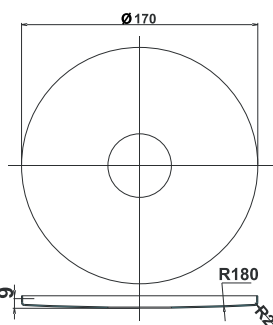

P. A. Harmony

Art. EAN pkg.
12256 3838963122562 12

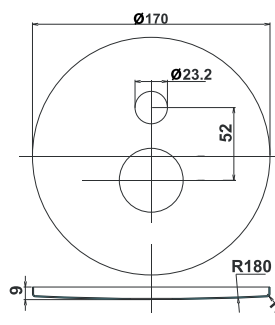

P. A. Prestige

Art. EAN pkg.
12257 3838963122579 12

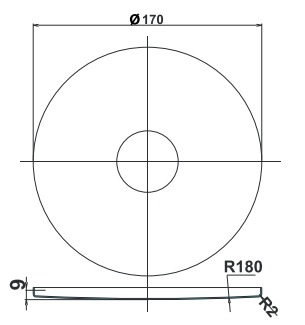

P. A. Prestige

Art. EAN pkg.
12258 3838963122586 12

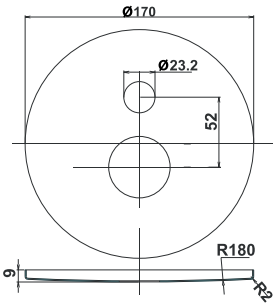

P. A. Masiva

Art. EAN pkg.
12101 3838963121015 8

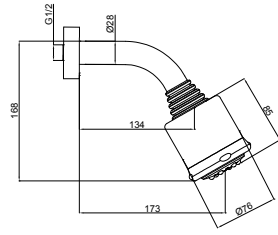

P. A. Prestige

Art. EAN pkg.
12201 3838963122012 12

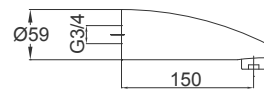

P. A. Prestige

Art. EAN pkg.
12102 3838963121022 1

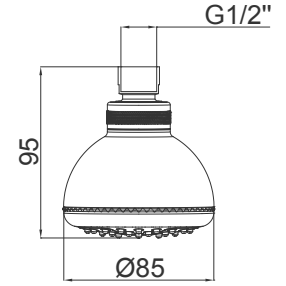

P. A. Pure

Art. EAN pkg.
12202 3838963122029 12

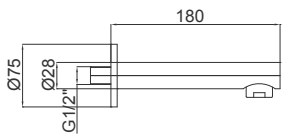

P. A. Pure

Art. EAN pkg.
12203 3838963122036 12

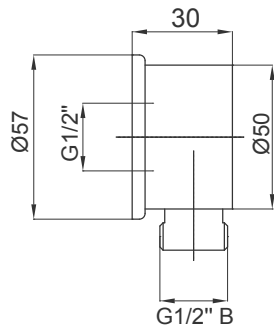

P. A. Prestige

Art. EAN pkg.
12204 3838963122043 12

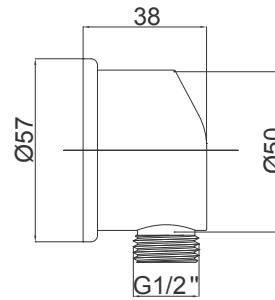

P. A. Prestige

Art. EAN pkg.
12206 3838963122067 12

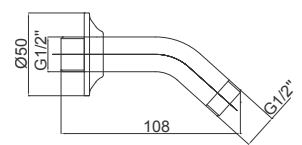

P. A. Pure

Art. EAN pkg.
12207 3838963122074 1

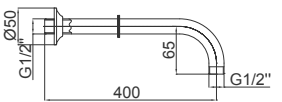

P. A.

Art. EAN pkg.
12208 3838963122081 1

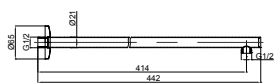

P. A.

Art. EAN pkg.
12209 3838963122098 1

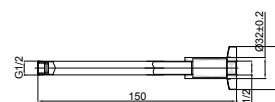

Art. EAN pkg.
12001 3838963120018 50

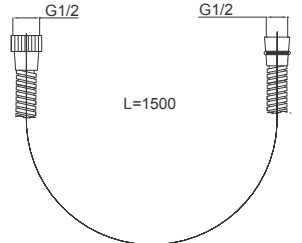

Pure Glossy

Art. EAN pkg.
12002 3838963120025 1

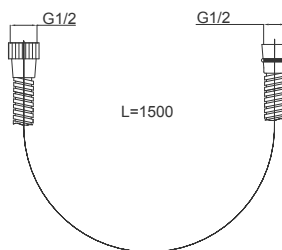

Art. EAN pkg.
12151 3838963121510 1

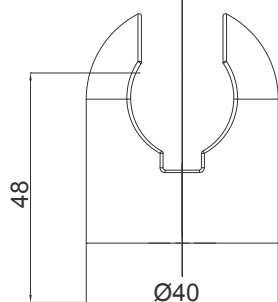

Pure

Art. EAN pkg.
12152 3838963121527 1

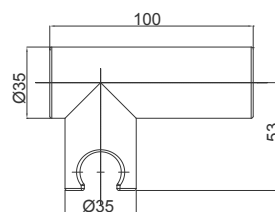

Prestige

Art. EAN pkg.
12153 3838963121534 1

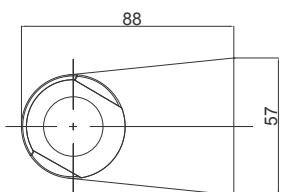

Fresh e66

Art. EAN pkg.
09511 3838963095118 8

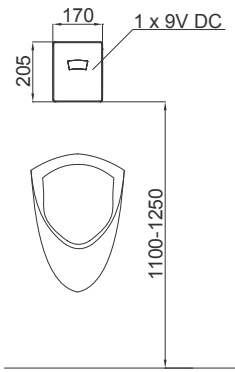

Fresh e66

Art. EAN pkg.
09512 3838963095125 8

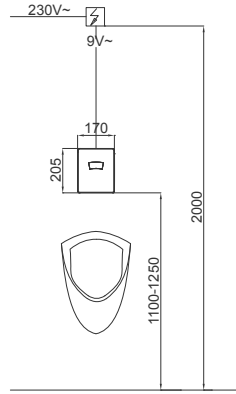

Fresh a14

Art. EAN pkg.
12357 3838963123576 12



Fresh a15

Art. EAN pkg.
12047 3838963120476 1

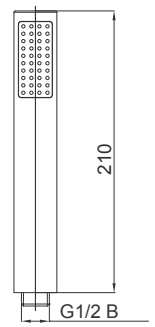

Prestige a17

Art. EAN pkg.
12351 3838963123514 8

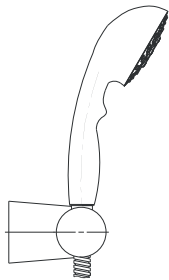

Prestige a18

Art. EAN pkg.
12044 3838963120445 1

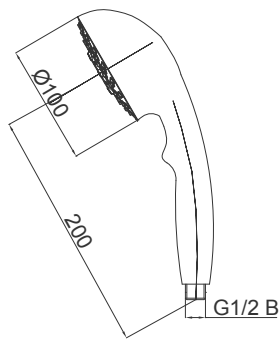

Simpaty a21

Art. EAN pkg.
12042 3838963120421 1

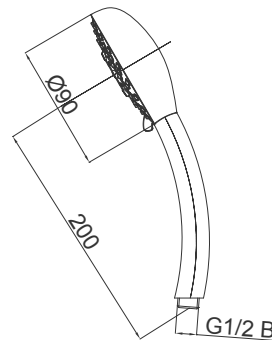

Project a24

Art. EAN pkg.
12041 3838963120414 1

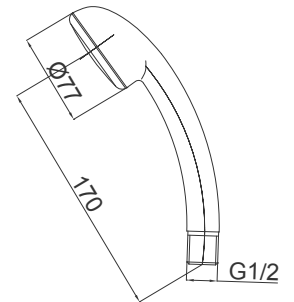

Nadglavna prha a08w

Art. EAN pkg.
12107 3838963121077 12

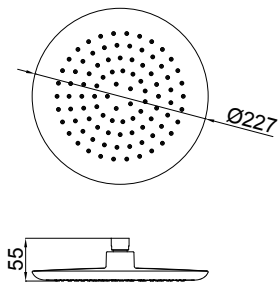

P. A.

Art. EAN pkg.
00369 3838963003694 12

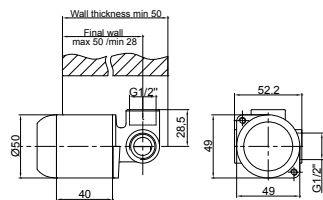

P. A.

Art. EAN pkg.
00370 3838963003700 12

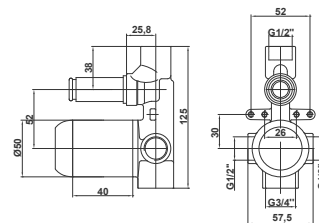

P. A.

Art. EAN pkg.
12248 3838963122487 12

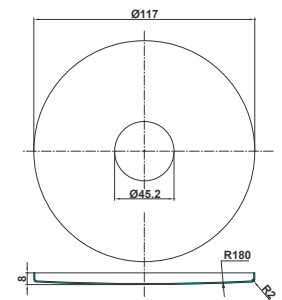

Index

Index
Содержание

Index

00001 16	00171 15	00427 55	01188 57	07554 70	12053 80	12654 90
00002 16	00172 15	00434 31	01189 57	07555 71	12101 98	12655 90
2 4215 61 104	00173 15	00435 31	01281 59	07558 70	12102 98	12701 95, 97
2 77665 4 104	00174 15	00437 33	01381 63	07559 71	12103 86	12702 97
00003 16	00175 14	00438 31	05055 74	08149 65	12104 86	12703 95
00004 16	00176 14	00440 33	05056 74	08150 64	12106 86	12704 39
00011 16	00181 58	00451 47	05154 72	08161 64	12107 86	12705 39
00012 16	00182 57	00452 47	05251 72	08163 65	12151 91	12706 39
00013 16	00183 58	00455 47	05252 73	08255 65	12152 91	13001 103
00014 16	00184 52	00480 60	05253 73	08266 64	12153 91	13002 103
00023 54	00185 52	00481 60	05351 76	09011 38	12154 90	13003 103
00024 54	00186 57	00482 60	05355 76	09013 38	12155 90	13004 103
00025 54	00188 57	00491 51	05451 77	09016 35	12201 98	13104 102
00026 54	00189 57	00492 51	05452 77	09017 35	12202 98	13108 102
00035 28	00190 57	00493 51	05454 77	09018 35	12203 99	13109 102
00037 63	00193 57	00501 19	05455 77	09019 35	12204 99	13110 102
00038 28	00235 27	00503 19	05553 75	09020 35	12206 99	13112 102
00039 28	00237 59	00515 54	05554 75	09021 35	12207 98	13113 102
00040 28	00251 43	00516 54	05557 75	09022 35	12208 99	13301 104
00044 30	00252 43	00518 54	06156 72	09023 35	12209 98	13401 104
00045 30	00281 59	00535 30	06158 72	09401 39	12248 95	16001 105
00048 28	00282 59	00536 30	06251 73	09402 39	12249 95	16002 105
00049 28	00291 48	00537 30	07061 68	09501 38	12250 95	16005 107
00051 45	00292 48	00551 45	07062 68	09502 38	12251 95	16201 105
00055 45	00301 20	00561 45	07063 69	09508 38	12252 95	16202 106
00061 45	00302 20	00571 45	07064 69	09510 36	12253 97	16204 105
00063 45	00303 20	00581 60	07066 68	09511 37	12254 97	16205 105
00071 45	00325 55	00582 60	07067 68	09512 37	12255 97	16206 106
00073 45	00326 55	00584 60	07068 69	10052 75	12256 97	16301 105
00081 60	00334 31	00591 51	07072 68	10151 75	12257 97	16302 106
00082 60	00335 31	00592 51	07073 69	10152 77	12258 97	16303 106
00083 60	00336 32	00594 51	07077 68	10251 74	12259 95	16305 106
00084 60	00337 31	01035 28	07078 69	10351 74	12260 95	16306 106
00091 50	00339 32	01081 60	07079 69	10352 74	12261 37	16401 107
00092 50	00352 47	01095 50	07156 65	10354 74	12263 37	16402 107
00093 50	00353 47	01132 42	07157 65	10355 75	12351 89	16404 107
00094 50	00356 47	01137 25	07158 64	10356 77	12352 81	16501 107
00129 25	00367 94	01138 23	07159 64	10451 76	12354 89	19001 108
00130 25	00368 94	01141 25	07162 65	10452 77	12355 90	19011 108
00131 25	00369 96	01142 25	07163 64	10551 75	12356 90	19021 108
00132 25	00370 96	01143 25	07165 65	10651 75	12357 88	19022 108
00133 25	00380 62	01144 25	07169 64	10652 76	12358 89	19023 108
00134 25	00381 62	01145 23	07260 67	12001 91	12451 82	19088 109
00135 23	00383 61	01146 23	07261 67	12002 91	12452 88	19123 109
00136 23	00384 62	01164 64	07262 67	12041 89	12455 90	19133 108
00137 26	00388 62	01169 13	07263 66	12042 89	12456 90	19145 109
00138 26	00389 62	01171 15	07264 66	12043 81	12460 82	19228 54
00144 23	00393 51	01173 15	07265 66	12044 89	12461 83	19412 103
00145 23	00394 51	01175 14	07357 70	12045 90	12462 83	19413 103
00146 23	00395 51	01181 58	07358 71	12046 90	12551 84	19504 109
00147 23	00401 21	01182 57	07462 70	12047 88	12552 84	21001 109
00151 42	00402 21	01185 52	07464 71	12050 80	12651 90	21161 109
00169 13	00403 21	01186 57	07465 70	12051 80	12652 90	
00170 13	00425 55	01187 57	07466 71	12052 80	12653 90	



We reserve the right to make technical changes and colour may vary due to the printing process.

v.1215

HERZ Armaturen Ges.m.b.H.

Richard-Strauss-Straße 22
A-1230 Wien

HERZ d.d.

Grmaška cesta 3
1275 Šmartno pri Litiji
Phone: +386 (0)1 896 21 02
Fax: +386 (0)1 896 21 40
e-mail: info@herz.si
www.herz-taps.com